

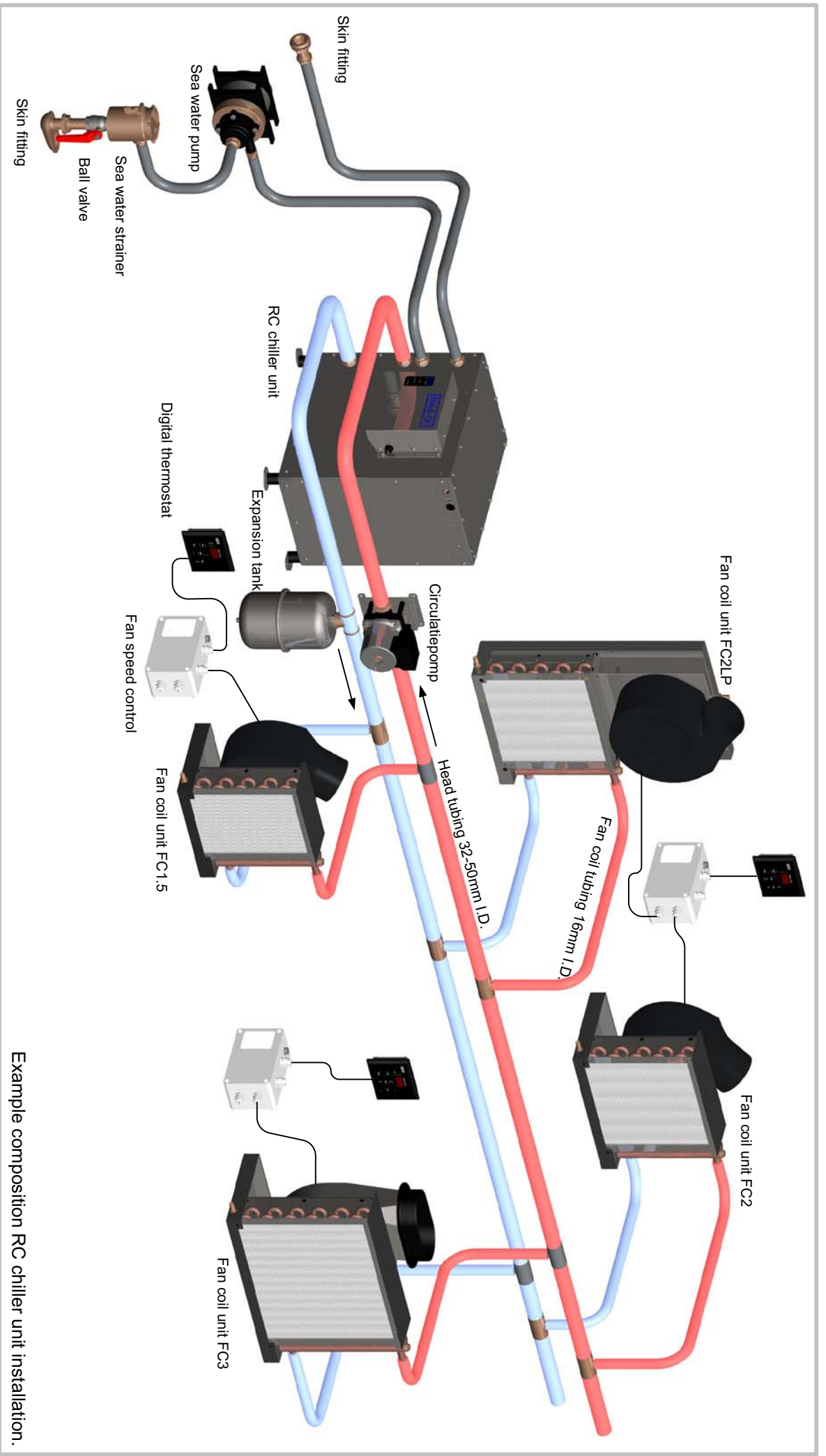

Marine air-conditioning systems

User & Installation
Manual

**Air-conditioning systems
A45RC**



Example composition RC chiller unit installation.

Contents

1.	Introduction and Safety measures	04
2.	Scope of supply	05
3.	Connections for sea/outside water	06
4.	Installation	07
5.	Condensation water drain	10
6.	Electrical connections	11
7.	Electrical scheme	14
8.	Technical data	15
9.	Dimensions	16
10.	Preparations for use	17
11.	Maintenance	18
12.	Preparing for winter	18
13.	Fault finding	19

1. Introduction

In this manual the installation, use and maintenance is described for the air conditioning systems as mentioned on the title page.

Please read this manual carefully and take note of the usage, installation and maintenance points given. This way malfunctions will be avoided and you will retain your warranty.

No special tools are required and neither is there a need for specific cooling technique knowledge. The technical installation for climate control can be found in the system cabinet.

When repairs or maintenance in this area are needed (system cabinet) this should always be done by certificated companies.

This airco should only be used for nautical purposes. Whenever changes have been made to the airco this will make the warrantee void, in these cases Mavé will not be responsible for possible damages. All risks are then exclusively for the user.

We have tried to make this manual complete with the use of schematics and figures while being as brief as possible. Nonetheless we are available for any queries you might have.

Safety measures

All relevant regulations and laws should be taken into account at all times when working with this product.

- Always use suitable tools for the job.
- Disconnect the power supply when working on the electrical system of this product.
- Never touch hot surfaces in or around the system cabinet.
- Never put combustible materials close to the installation.
- Disconnect the installation when welding close to the installation.
- Never touch moving parts when the installation is in use.

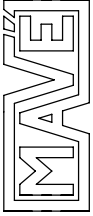

NAUTIC & INDUSTRIAL ENGINEERING
 Lisdoddeweg 21
 8251 SM Dronen, The Netherlands
 tel.+31 321 337467 fax +31 321 337542
 info@mave.nl www.mave.nl

A45RC scope of supply

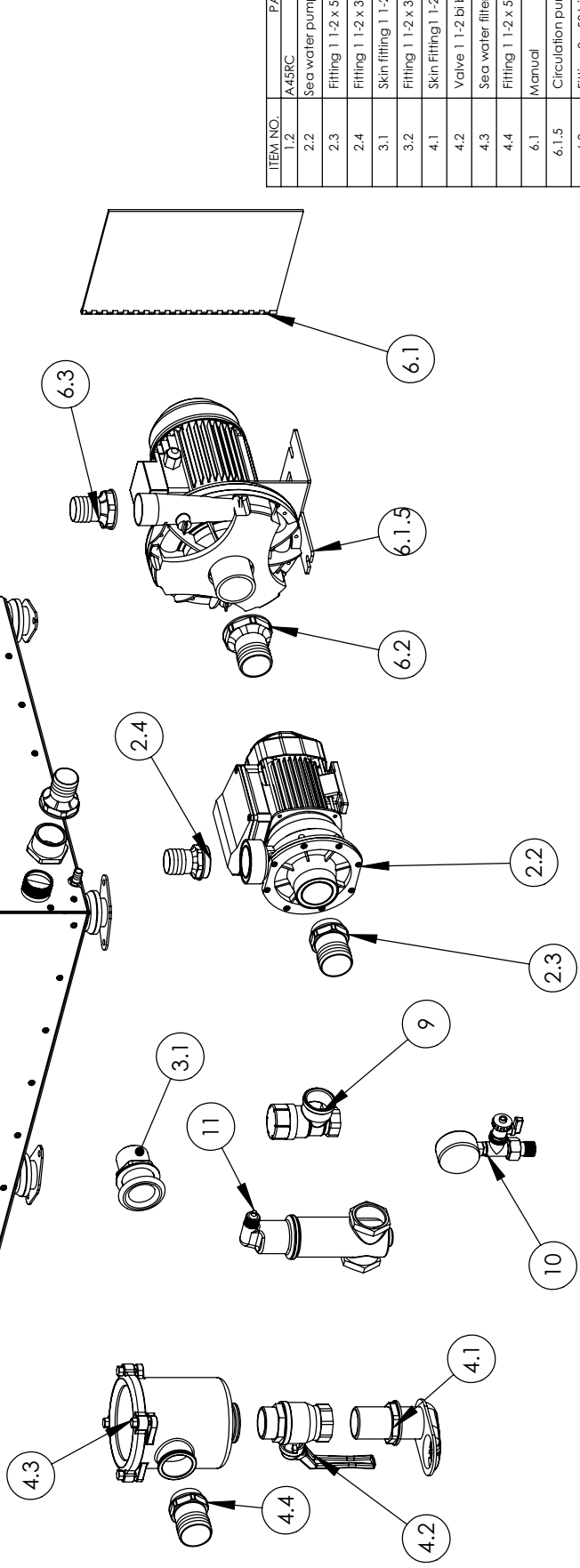
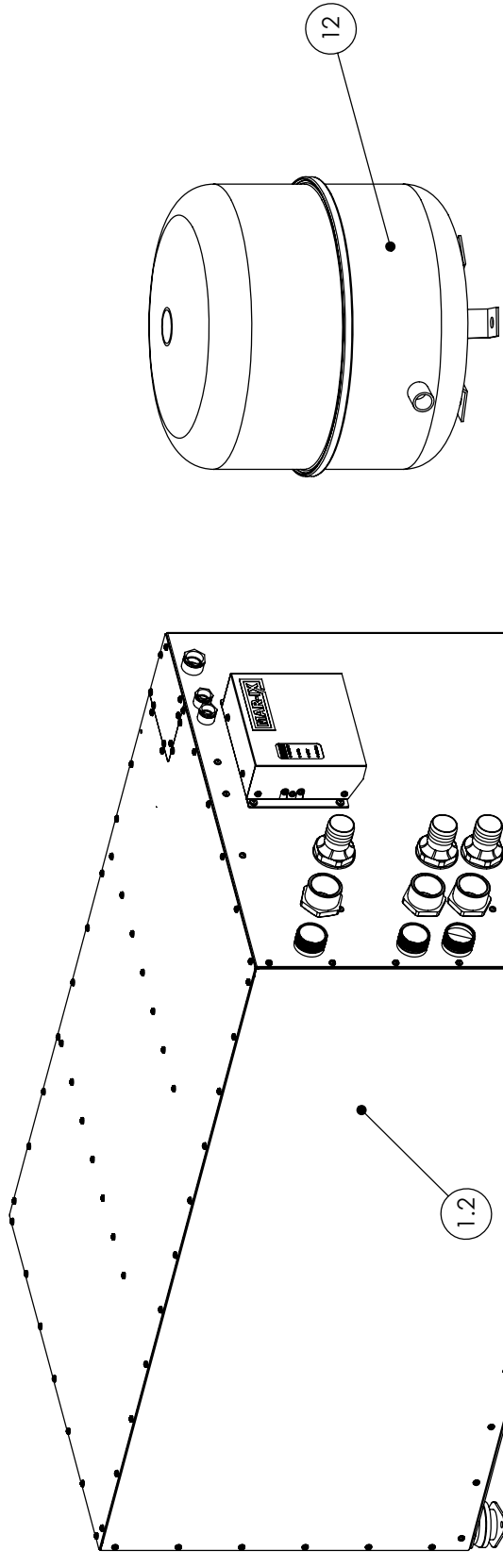

ITEM NO.	PART NUMBER	PartNo	QTY.
1.2	A45RC		1
2.2	Sea water pump	N10280	1
2.3	Fitting 1 1-2 x 50 bu	B20644	1
2.4	Fitting 1 1-2 x 38 bu	B20643	1
3.1	Skin fitting 1 1-2 bu	B20640	1
3.2	Fitting 1 1-2 x 38 bi	B20642	1
4.1	Skin Fitting 1 1-2 bu	B20641	1
4.2	Valve 1 1-2 bi bu	B20650	1
4.3	Sea water filler 1 1-2 bi	B20651	1
4.4	Fitting 1 1-2 x 50 bu	B20644	1
6.1	Manual		1
6.1.5	Circulation pump BAC40-12?	N20477	1
6.2	Fitting 2 x 50 bi	B20652	1
6.3	Fitting 1 1-2 x 38 bi	B20642	1
1	Reduce fitting 1 1-2bu x 1 1-4 bi	B20647	4
8	Fitting 1 1-2 x 38 bi	B20642	4
9	Overpressure valve 1.5bar	N50550	1
10	Fill valve and pressure gauge	N50549	1
11	Air vent 1 1-2	N50548	1
12	Expansion reservoir 35L Flamco	N20623	1

3. Connections for sea water and/or outside water

The airco A45RC is an air conditioning system which uses water for cooling. All excess heat in the boat will be transferred to water which is then pumped outside. The external water system consists of an outside water pump, filter and a number of fittings.

Installation:

Install the skin through hull fitting with water scoop (B20641) in a low point of the ship where water is always available. Install the water intake in the direction the ship is normally going. Take care that the water intake is never placed near a drainage for a toilet, kitchen and/or bathroom. **Never** combine the outside water system with that of another system (such as the engine).

Install the outside water pump as shown in the figure below. Take care to place the outside water pump at least 25 centimetres below the waterline of the ship. This position is necessary because the pump is **not** self-priming.

A valve (B20650) and water filter (B20651) are part of the scope of supply. These parts should be installed directly on the skin through hull fitting. Use suitable material for making a water tight seal when screwing on these parts.

Install the skin through hull fitting (B20640) on the hull of the ship on the water line.

Connect components of the outside water system with the sea water resistant hose of 38-50 mm diameter (internal) as shown in the figure below. Always use 2 hose clamps for each connection on hoses placed below the waterline of the boat. Make sure that the hoses do not create tension on the housing of the outside water pump.

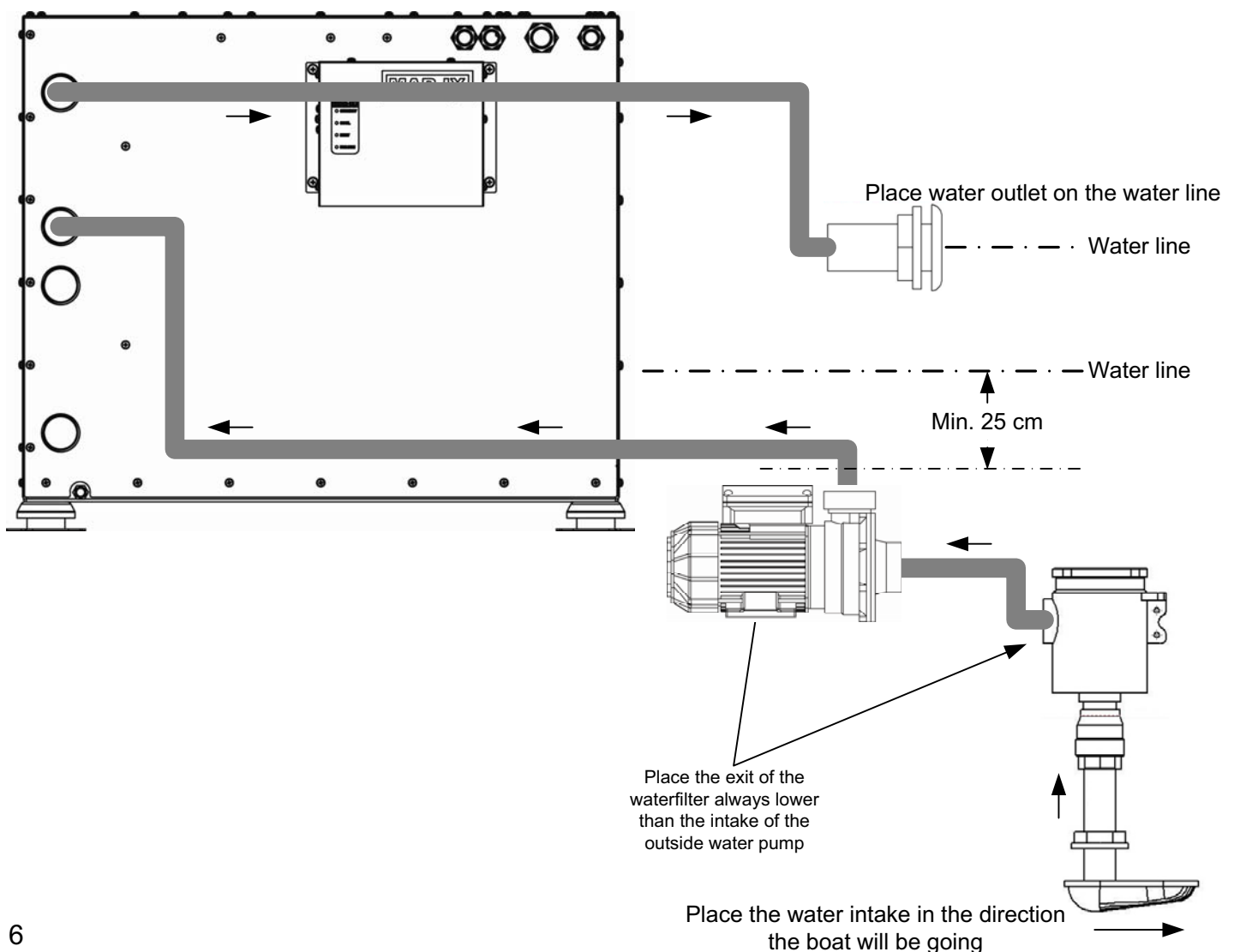

4. Installation

The way in which the closed cooling liquid system is built is shown in the figures on the next 2 pages.

Installation:

It is recommended first to determine where the main components will be placed.

For the piping can be used several materials like plastic or metal. The piping has to be resistant for glycol, temperatures between 0 and 50°C, and a pressure of 2 bar.

It will be recommended to place 2 ball valves on the in and output of the chiller glycol system in case of maintenance.

It will also be advised to use two short flexible hoses on the chiller to avoid that the vibration of the chiller will pass through the piping system.

To be sure that every fancoil unit has nearly the same flow, it will be recommended that the piping of the fancoils (Ø16) have approximately the same length.

After this the placement of the main piping can be determined. It is recommended to install these piping with insulation material in one attempt from the front to the back end of the ship and to mark these hoses as supply and return.

We advise to pressurize the system using **max. 1 bar** of air pressure and to check afterwards for leaks using soapy water. After this the fittings need to be insulated with insulation tape. This is to prevent condensation of the blank parts.

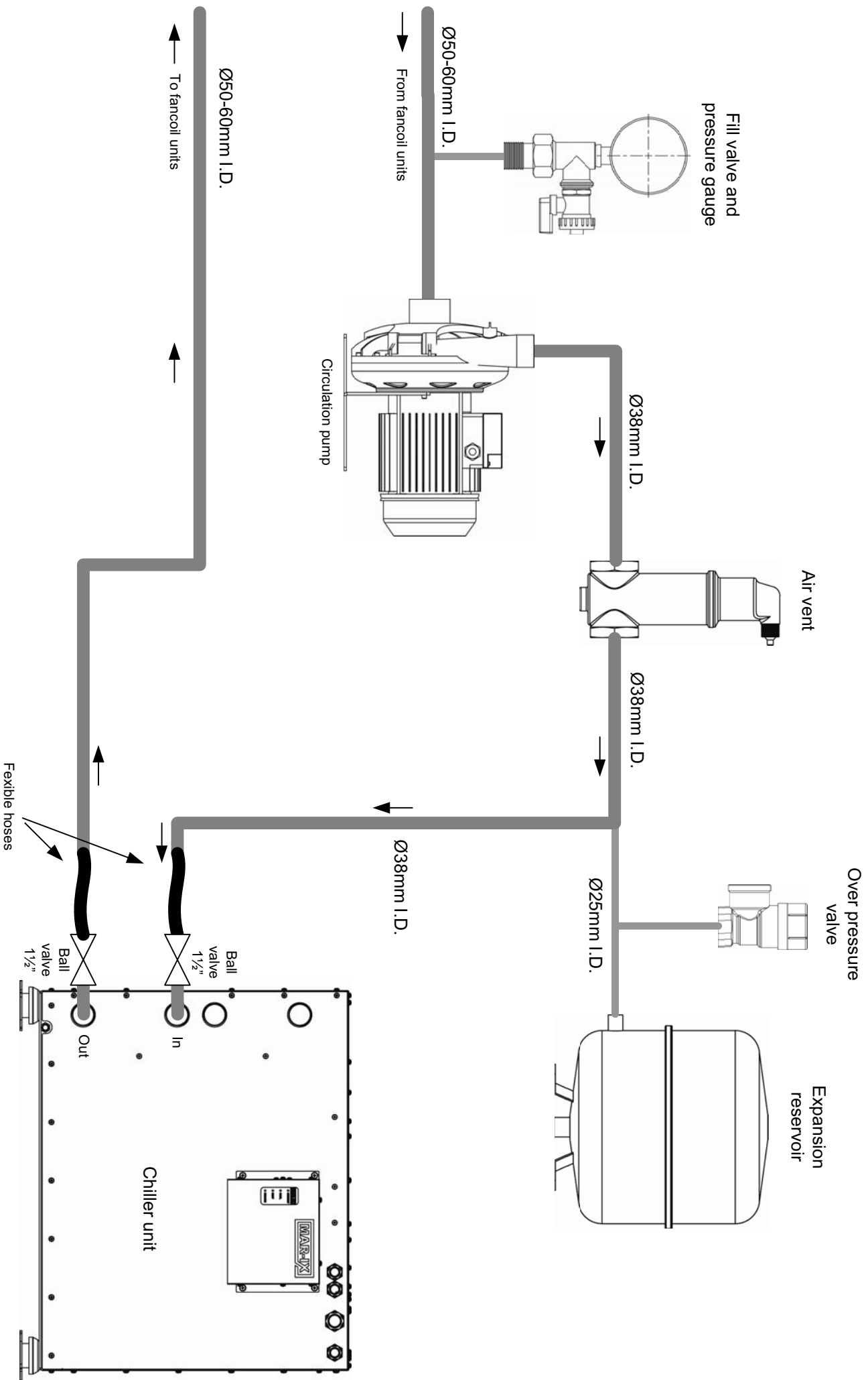

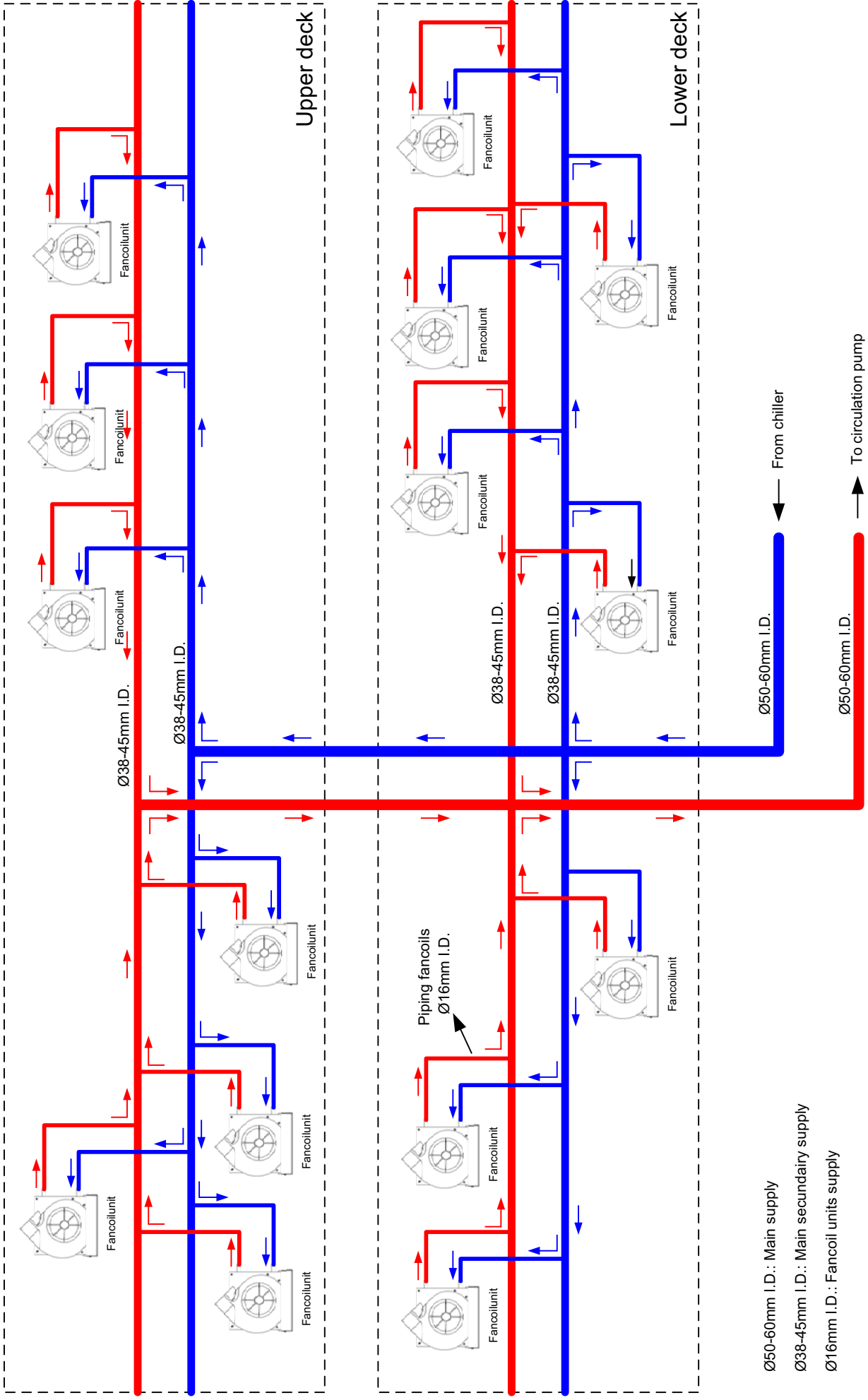

5. Condensation water drain

When the air conditioning system is running it will produce condensed water.

A drainage for condensed water is mounted in the system cabinet which collects this water. How much water will be produced depends on the humidity of the air. The condensed water has to be drained from the system continually which can be done in several ways:

- By a skin through hull fitting direct to the outside water.
- By a connection on the drainage of the sink.
- By a connection on a shower water pump or drainage pump.
- By a connection on the outlet hose of toilet or bilge water tank.
- By a connection to the end of the bilge pump outlet.

Make sure the drainage system is not blocked for draining water from the air conditioning system.

When a connection to a toilet water or bilge water tank is used then always insert a swan's neck or siphon to prevent bad smells. It is advised to fill the swan's neck or siphon partly with salad oil which vaporizes only little and will prevent that the swan's neck or siphon will become dry.

On the lower side of the system cabinet is a drainage for condensed water (see figure). This drainage will hardly produce any water at all. Still it is advised to make a connection to above mentioned systems too.

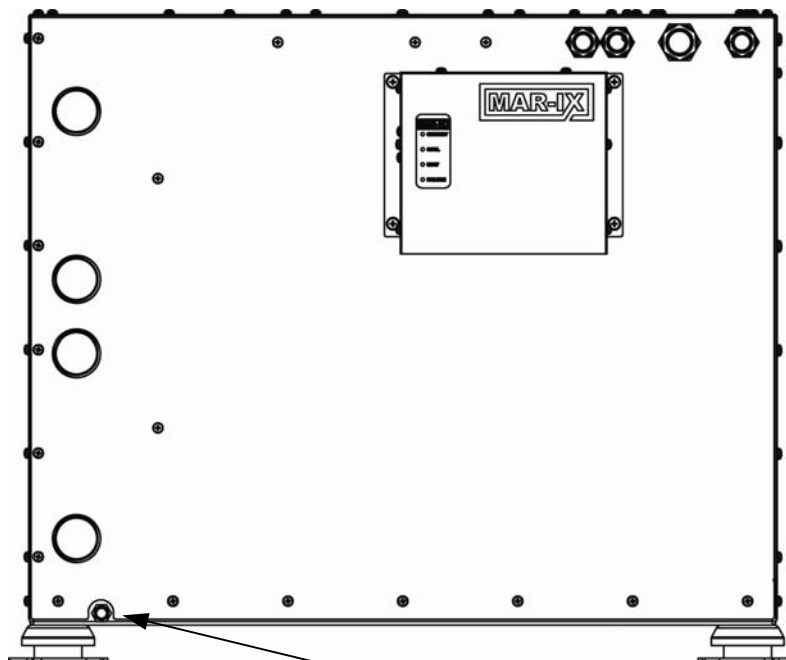

Condensation water drain

6. Electrical connections

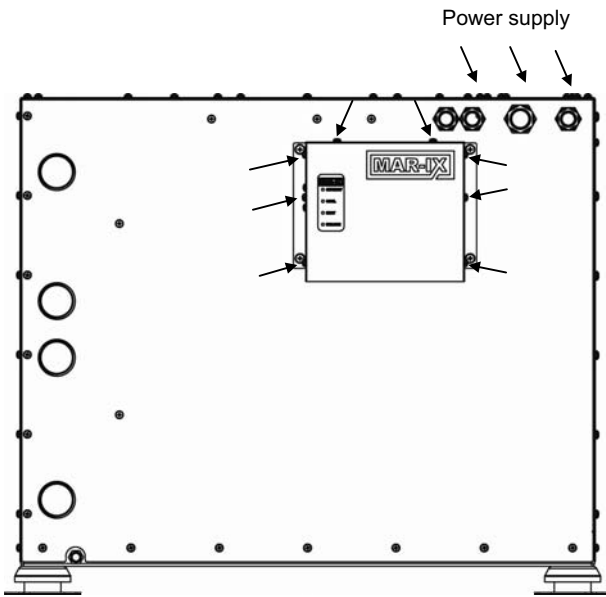

To get access to the electrical connections you need to undo the screws which are indicated by arrows in the figure on the left. Next take off the front and the top panel.

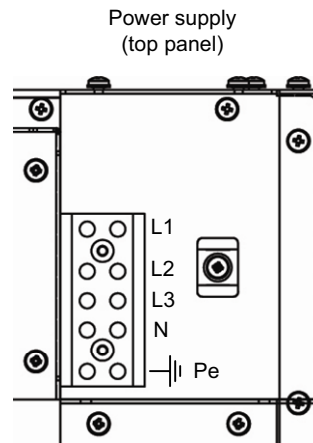

After taking of the front panel the electrobox is visible. In the figure below an schematic overview is given of the components which need to be connected. On the next page the connection are shown.

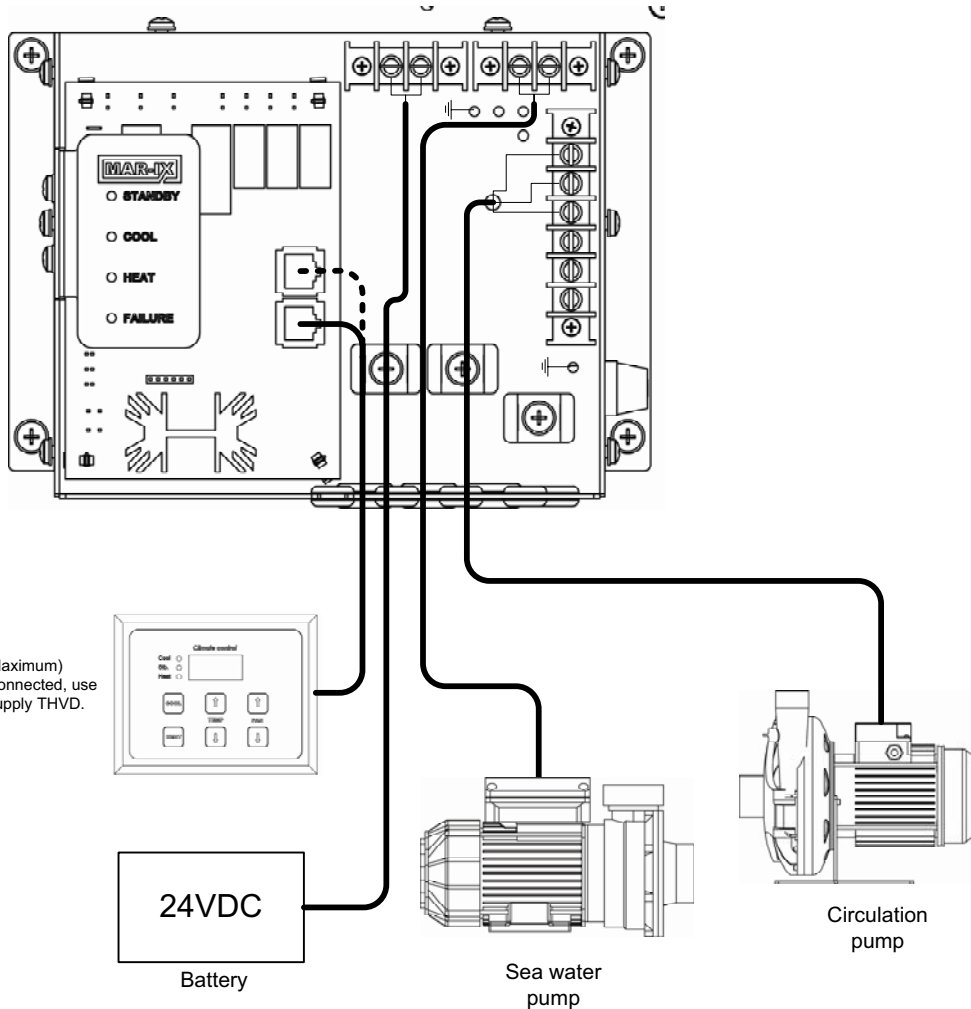

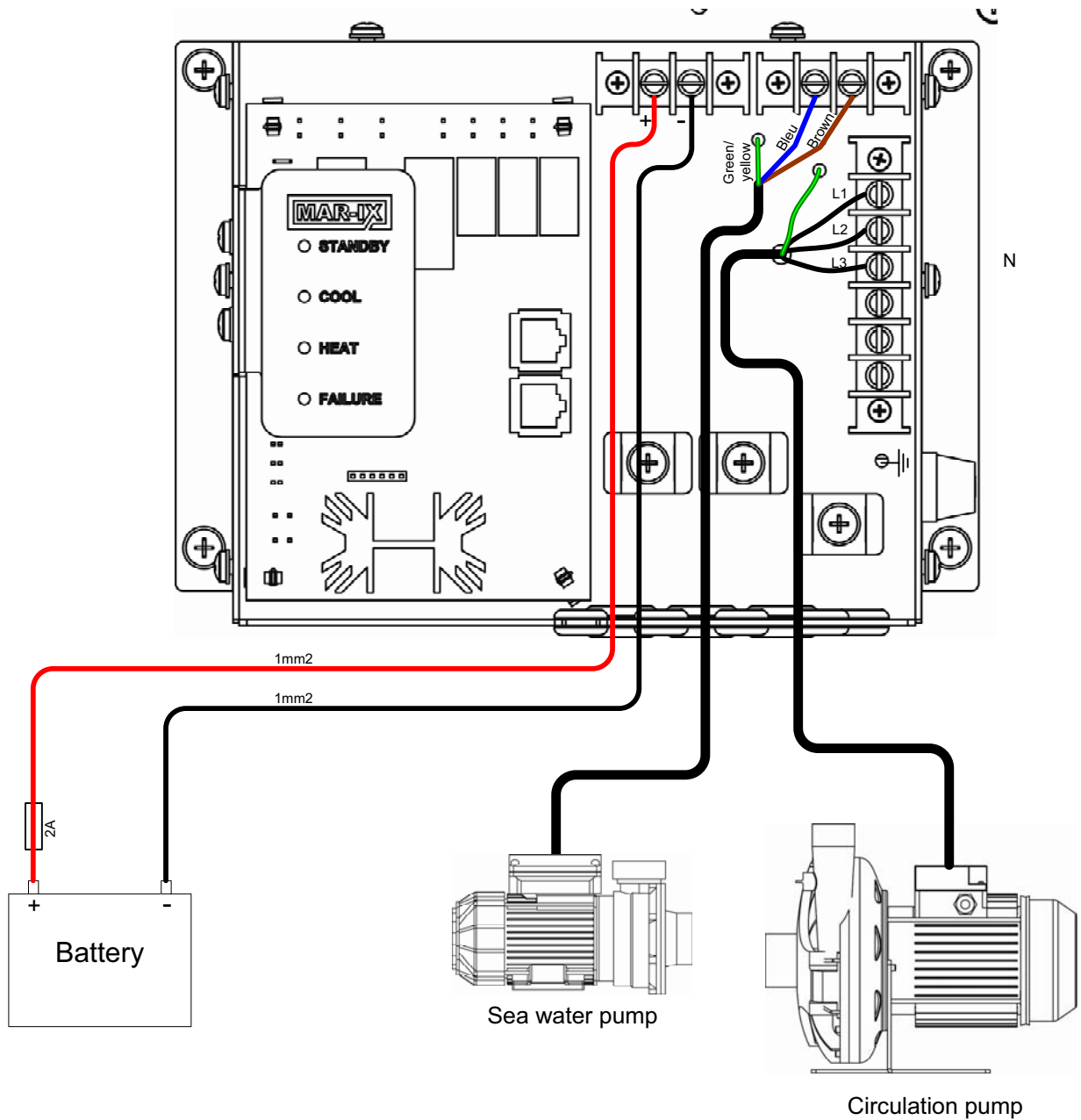

Connections:

The battery is connected using a cable with a minimum of 1 mm². A fuse of 2A must be used.

The cirulation pump and sea water pump need to be connected as indicated in the figure above. The ground cable needs to be connected using the connection on the bottom panel of the electrobox.

The supplied circulation pump is a 3 phase 380v pump, and the outside water pump is a 230v single phase pump.

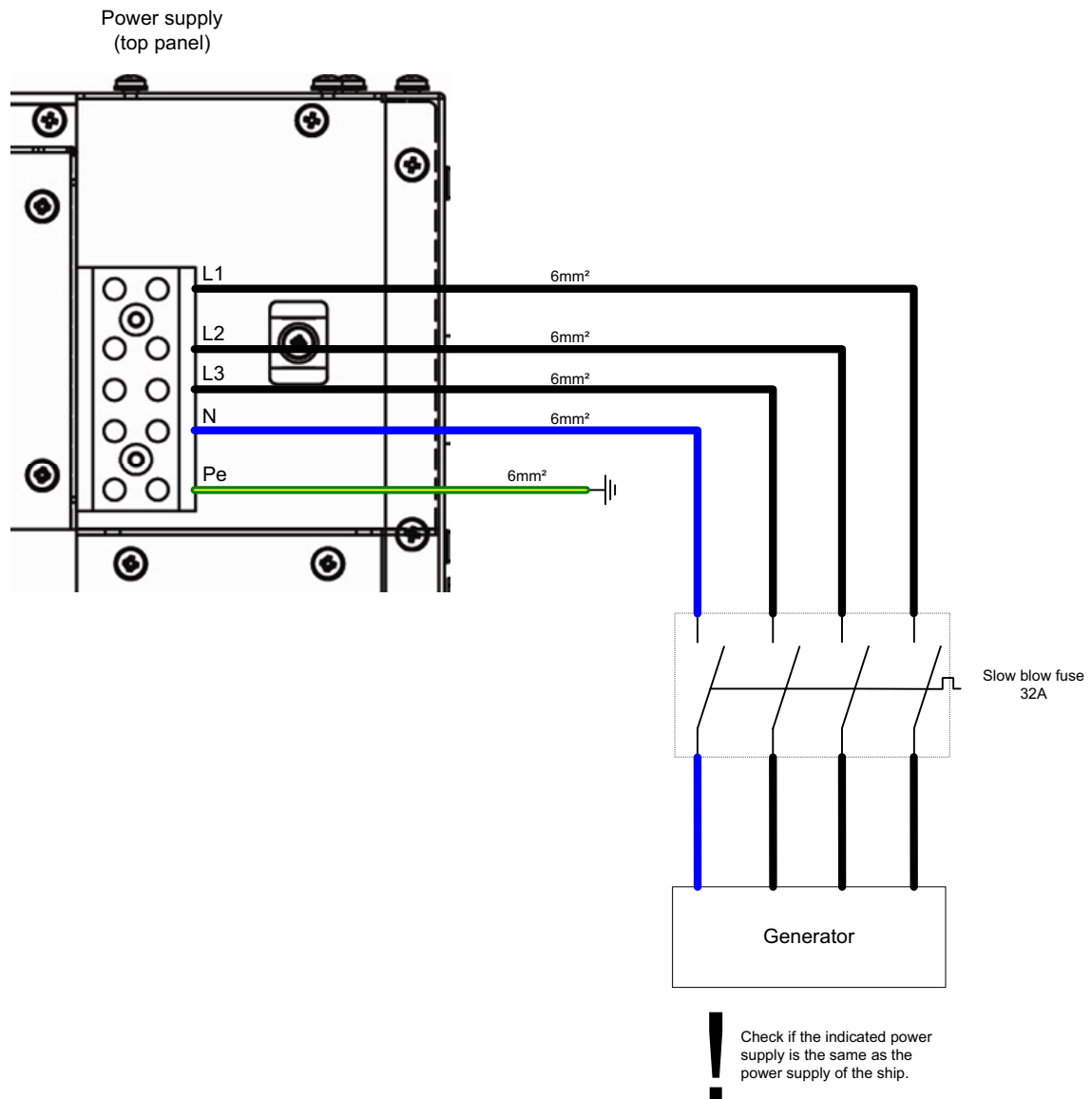

Connections:

The power supply must be connected by using a cable with a minimum of 6 mm² which is suitable for 380 volt alternating current and a slow blow fuse of 32A needs to be used.

Check if the voltage and frequency of the boat are similar to the indicated voltage and frequency on the system label of the system cabinet.

The connecting of the thermostat is described in the manual of the thermostat itself, this is because the connections can be difference for each type.

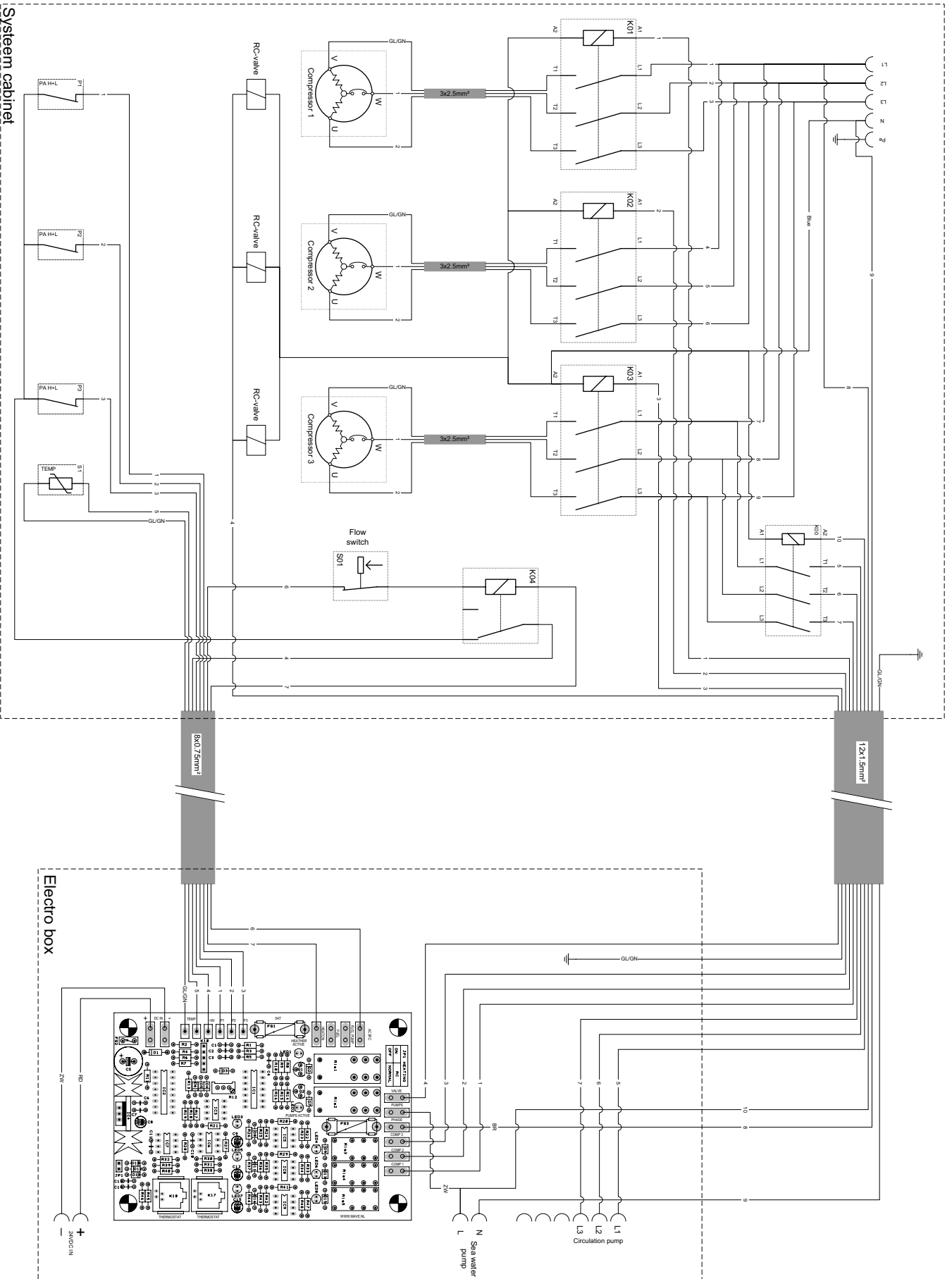

A45RC Internal schedule

8. Technical data

A45RC	
<i>Dimensions (lxwxh)</i>	1146x660x570 mm
<i>Weight</i>	300 kg
<i>Cool capacity</i>	45 kW (153.600 Btu)
<i>Refrigerant</i>	3300 gram R407C
<i>Number of compressors</i>	3
<i>Voltage</i>	380v/50Hz L3+N+Pe and 12-24v dc
<i>Heat capacity</i>	up to 60 kW
<i>Power intake AC</i>	10.800 watt
<i>Outside water connection</i>	G1 1/4" ot
<i>Chilled water connection</i>	G1 1/4" ot
<i>Max. environmental temperature</i>	40°C
<i>Max. temperature outside water</i>	35°C

Description of the above mentioned system

The above mentioned system is equipped with 3 rotary compressors and is filled with an environmentally friendly R407C cooling gas.

The casing is made of corrosion resistant steel 304.

The water cooled condensor is built up using a sea water resistant copper/nickel.



NAUTIC & INDUSTRIAL ENGINEERING

Lieddeweg 21
8251 SM Dordten, The Netherlands
tel. +31 321 337467 / fax +31 321 337542
info@mave.nl www.mave.nl

A45RC Dimensions

Size	Scale	Projection
A3	1:8	

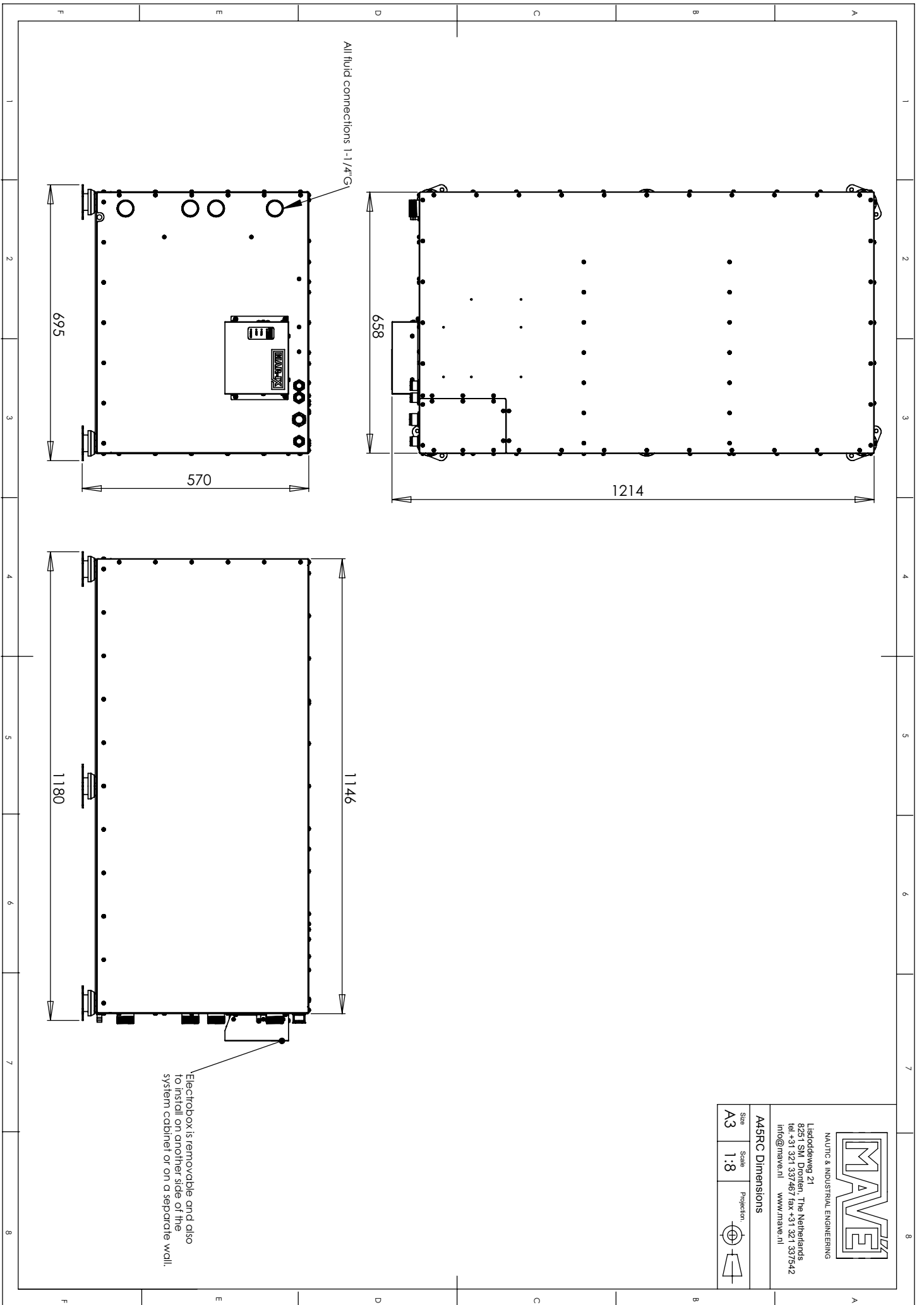

10. Preparations for use

After installation of the complete system, it needs to be put in operation for the first time. The following steps must be taken in the given order;

Connect a standard electric plug to the circulation pump.

- Fill the closed liquid system with a cooling liquid or antifreeze diluted with water until 0.3bar
The liquid must be resistant to a minimum temperature of -15°C.
- Now the circulation pump must be switched on (on the standard electric plug).
Make sure the pump is running in the right direction!
- Refill the closed liquid system up until ± 0.3 bar, the circulation pump will pump the fluid through the system.
- Bleed all the fan coil units of air by screwing loose the nipples for taking air bubbles out on top of the fan coil units. Be sure the system stays in a overpressure, refill if necessary.
- Let the circulation pump run several ours to be sure the system is free of air.
- Reconnect the circulation pump according to the scheme on page 9.
- Open the water valve on the outside water system.
- Turn on the power supply of the airconditioning system (AC and DC power supply).
- Set one of the thermostats in cooling modus.
(see manual for the thermostat).
- Check if the compressors run in the right direction.
- Check if the water of the outside water systems runs through well.

It will be advised to check the whole system if the temperature true all the fancoil units is cooled down untill $\pm 5^{\circ}\text{C}$.

- Switch off the thermostat (Cooling modus) and switch on the thermostat heating modus.
- Check if the temperature in the glycol system heated up. (Until $\pm 35^{\circ}\text{C}$)

Check in the first period of use the system on leaks and air in the glycol system.

The chiller glycol system is a low pressure system (0.3Bar), do **NOT** over pressurize the system!

The system is now ready for use.

11. Maintenance

Outside water filter: Clean the filter depending on your level of use, but at least once every 3 months.

Close the outside water valve (B20650) beneath the filter.
Remove the cover from the filter.
Take out the filter element and clean the filter by using a brush and water until residue and filth is removed.
Check after reinstalling the filter and opening the outside water valve, if the filter cover does not leak any water.

Condensator: The condensator which is cooled by outside water must be decalcified at least once every year.

Close the outside water valve (B20650) beneath the filter.
Remove the water out of the sea water system by screwing loose both of the connections of the condensator.
Connect the lower hose back on the condensator.
Use the upper hose to fill the system with cleaning vinegar (8%).
Let the system stand filled with cleaning vinegar for at least 2 days.
Check after reassembly and opening of the outside water valve if the hoses connected to the condensator do not leak any water.

12. Preparing for winter

If the boat during winter will be subjected to the temperatures below freezing point then the water must be removed from the outside water system and must be completely flushed through with antifreeze.

Take off the hoses from the chiller and let the system empty as far as possible.

Reconnect the lower tube to the condensator.

Fill the condensator using the upper connection with antifreeze until it runs out of the ship.

Make sure no water can get into the system afterwards.

In areas where there will be no temperatures below freezing point the outside water system must be filled with fresh water or cleaning vinegar.

Check if the closed glycol system freezing point is below the winter period temperature.

13. Fault finding

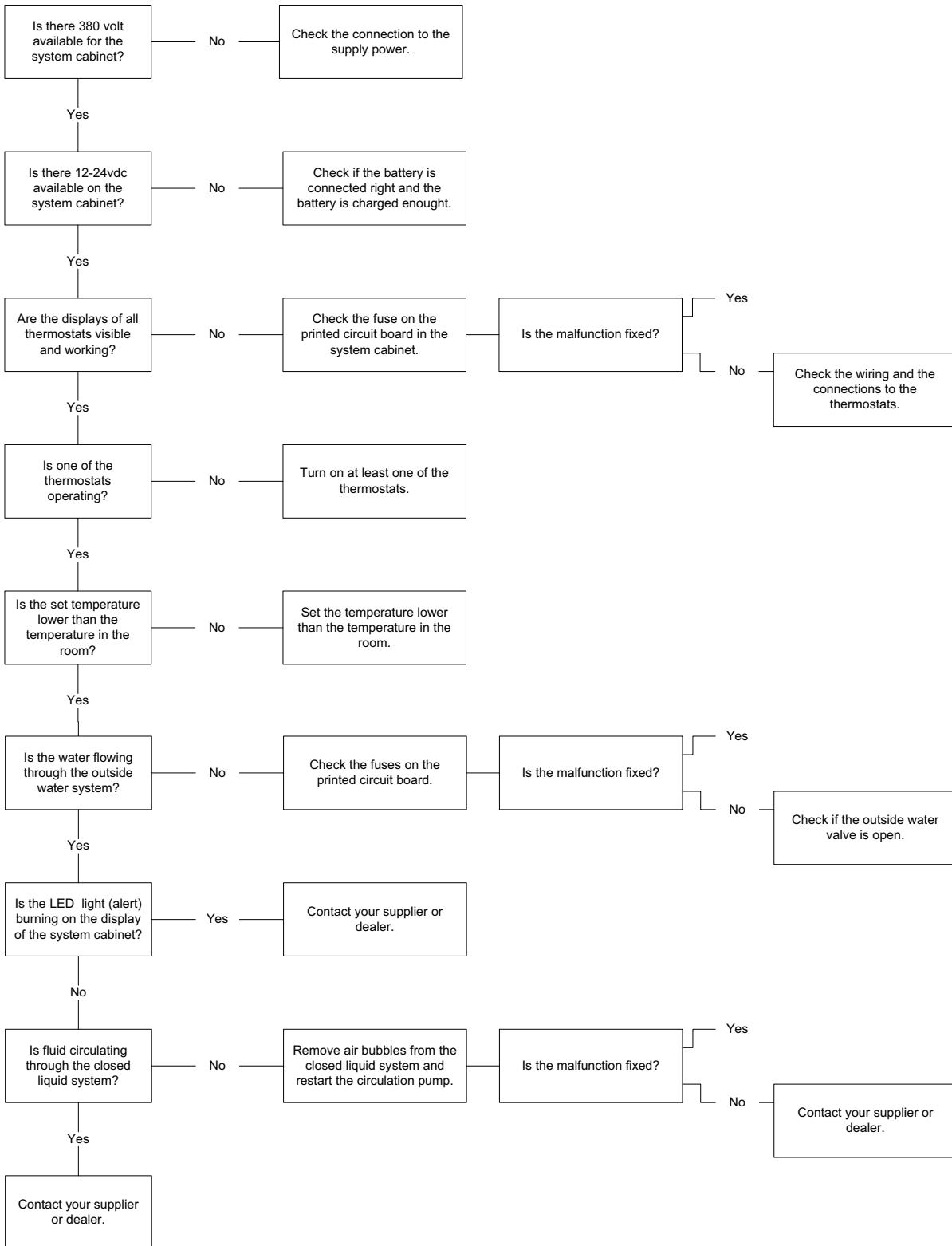

Declaration of Conformity

Mavé B.V. the Netherlands, certifies that all manufactured chillers and AC units have been tested and subjected to the following test procedures:

Pressure test.

The complete installation has been pressure tested with dry N2 according to European and Dutch regulations.

All units have been tested on at least 1.0 times the maximum working pressure with a maximum of 1.3 times the maximum working pressure.

The design pressure of any component is not lower than the maximum working pressure of the refrigeration system or section of the system in which that component is used.

During the testing period the installation has been checked on leakage and deformation.

Testing values.

R410a units.

This testing pressure on the low pressure side was ≥ 2500 KPa(g) $\approx 43^\circ\text{C}$.

This testing pressure on the high pressure side was ≥ 2600 KPa(g) $\approx 43^\circ\text{C}$. (water cooled)

R407c units.

This testing pressure on the low pressure side was ≥ 1750 KPa(g) $\approx 43^\circ\text{C}$.

This testing pressure on the high pressure side was ≥ 1750 KPa(g) $\approx 43^\circ\text{C}$. (water cooled)

R134a units.

This testing pressure on the low pressure side was ≥ 1000 KPa(g) $\approx 43^\circ\text{C}$.

This testing pressure on the high pressure side was ≥ 1000 KPa(g) $\approx 43^\circ\text{C}$. (water cooled)

Vacuum test.

Installations with a refrigerant charge < 10 kg.

A vacuum test has been performed by a vacuum of < 270 Pa and a minimal holding period of 30 minutes.

Refrigerant charge.

The unit has been charged according the number of kilograms mentioned on the identification plate.

Guidelines and environment.

Mavé B.V. the Netherlands commits herself to deliver the refrigeration installation according to the:

- EN 378 European safety and environment regulations for refrigeration installations and heat pumps
- CE standard
- The Dutch regulations on leak-free refrigeration equipment version 1997 or later.

M. Vermetten,

Managing director Mavé B.V.



Lisdoddeweg 21 - 8251 SM Dronten - The Netherlands
Tel.: +31(0)321-337467 - Fax: +31(0)321-337542
Web: www.mave.nl - Email: info@mave.nl