

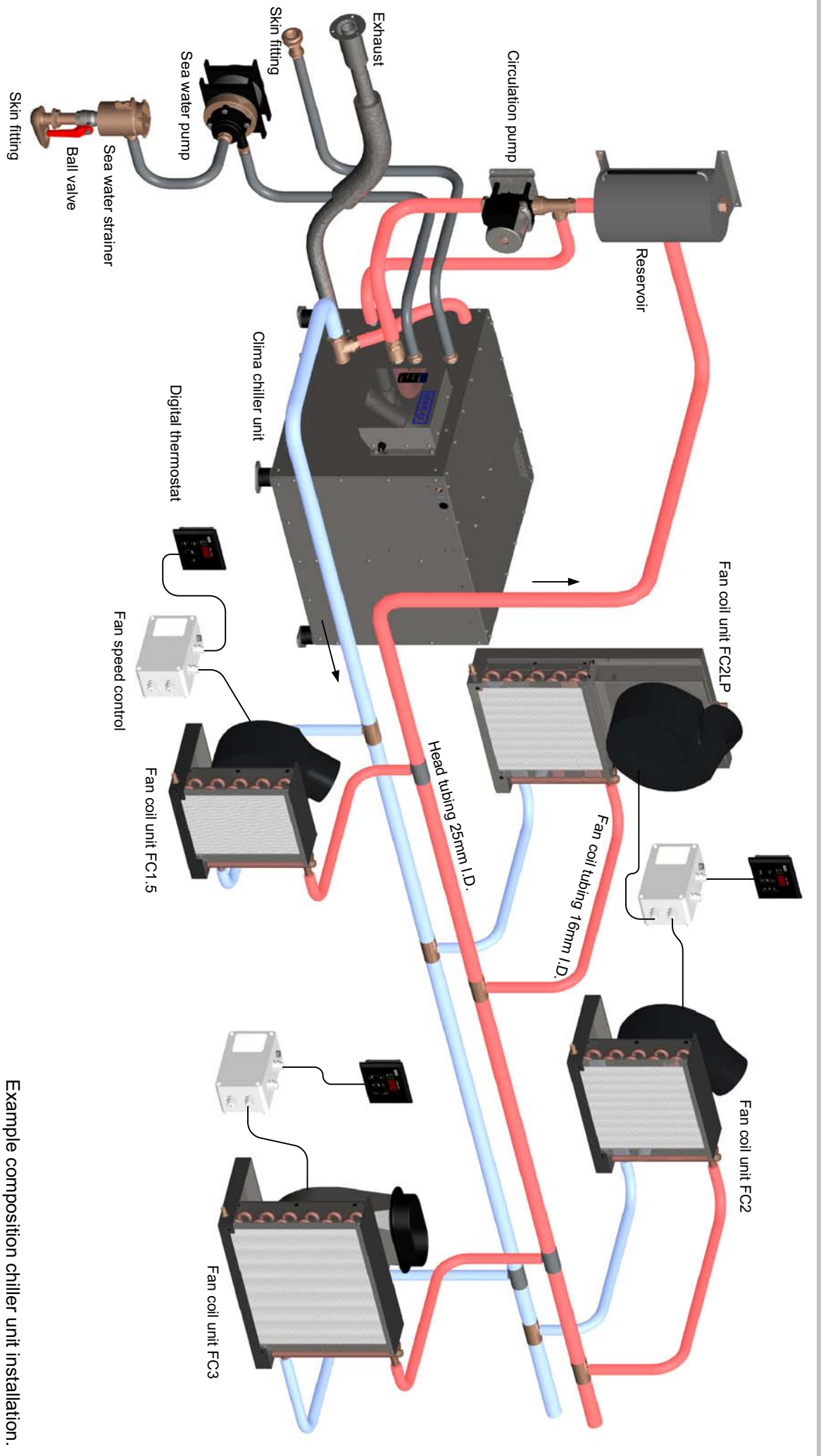

Marine air-conditioning systems

User & Installation
Manual

**Air-conditioning systems
C15**



Example composition chiller unit installation.

Contents

1.	Introduction and Safety measures	04
2.	Scope of supply	05
3.	Connections for sea water and/or outside water	06
4.	Installation	07
5.	Exhaust system	09
6.	Fuel supply	10
7.	Condensation water drain	11
8.	Electrical connections	12
9.	Electrical scheme	14
10.	Technical data	15
11.	Dimensions	16
12.	Preparations for use	17
13.	Maintenance	18
14.	Preparing for winter	18
15.	Fault finding (airco function)	19
16.	Fault finding (heating function)	20

1. Introduction

In this manual the installation, use and maintenance is described for the air conditioning systems as mentioned on the title page.

Please read this manual carefully and take note of the usage, installation and maintenance points given. This way malfunctions will be avoided and you will retain your warranty.

No special tools are required and neither is there a need for specific cooling technique knowledge. The technical installation for climate control can be found in the system cabinet.

When repairs or maintenance in this area are needed (system cabinet) this should always be done by certificated companies.

This airco should only be used for nautical purposes. Whenever changes have been made to the airco this will make the warrantee void, in these cases Mavé will not be responsible for possible damages. All risks are then exclusively for the user.

We have tried to make this manual complete with the use of schematics and figures while being as brief as possible. Nonetheless we are available for any queries you might have.

Safety measures

All relevant regulations and laws should be taken into account at all times when working with this product.

- Always use suitable tools for the job.
- Disconnect the power supply when working on the electrical system of this product.
- Never touch hot surfaces in or around the system cabinet.
- Never put combustible materials close to the installation.
- Disconnect the installation when welding close to the installation.
- Never touch moving parts when the installation is in use.



NAUTIC & INDUSTRIAL ENGINEERING

Lisoddeweg 21
8251 SM Dronten, The Netherlands
tel.+31 321 337467 fax +31 321 337542
info@mave.nl www.mave.nl

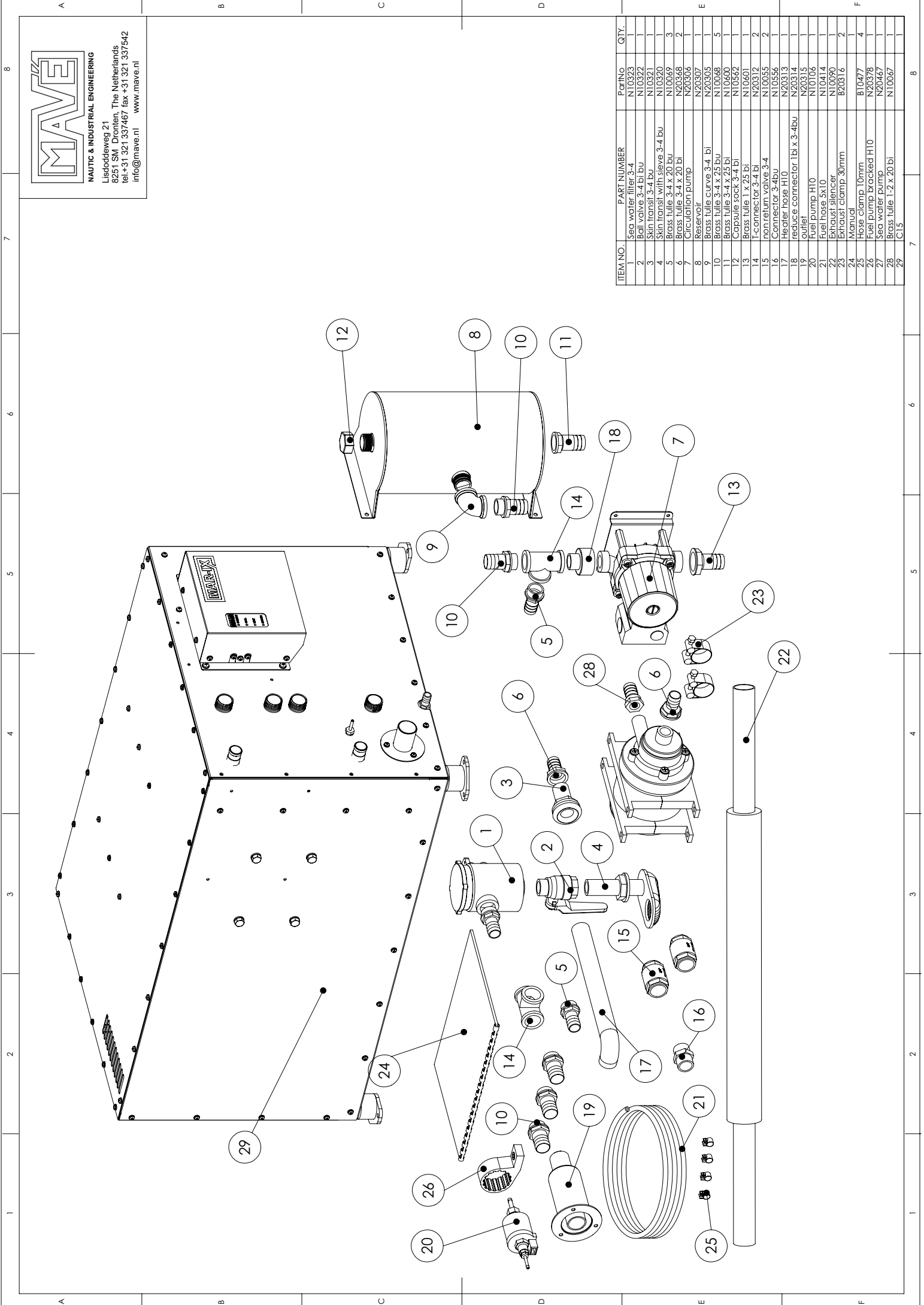

ITEM NO.	PART NUMBER	PartNo	QTY.
1	Sea water filter 3-4	NI10323	1
2	Ball valve 3-4 bi bu	NI10322	1
3	Skin transit 3-4 bu	NI10321	1
4	Skin transit with sieve 3-4 bu	NI10320	1
5	Brass tulle 3-4 x 20 bu	NI10049	3
6	Brass tulle 3-4 x 20 bi	N203048	2
7	Circulation pump	N203006	1
8	Reservoir	N203007	1
9	Brass tulle curve 3-4 bi	N203005	1
10	Brass tulle 3-4 x 25 bu	NI10048	5
11	Brass tulle 3-4 x 25 bi	NI10600	1
12	Capsule sock 3-4 bi	NI10562	1
13	Brass tulle 1 x 25 bi	NI10601	1
14	I-connector 3-4 bi	N203012	1
15	non return valve 3-4	NI10055	2
16	Connector 3-4bu	NI10556	1
17	Heater hose H10	N203013	1
18	reduce connector 1 bi x 3-4bu	N203014	1
19	ouilet	N203015	1
20	Fuel pump H10	NI10414	1
21	Fuel hose 5x10	NI10414	1
22	Exhaust silencer	NI10090	1
23	Exhaust clamp 30mm	B203016	2
24	Manuai		1
25	Hose clamp 10mm	B10477	4
26	Fuel pump bracketed H10	N203078	1
27	Sea water pump	N20467	1
28	Brass tulle 1-2 x 20 bi	NI10067	1
29	C15		1

3. Connections for sea water and/or outside water

The airco C15 is an air conditioning system which uses water for cooling. All excess heat in the boat will be transferred to water which is then pumped outside. The external water system consists of an outside water pump, filter and a number of fittings.

Installation:

Install the skin through hull fitting with water scoop (N10320) in a low point of the ship where water is always available. Then install the water scoop in the direction the ship is normally going. Take care that the water intake is never placed near a drainage for a toilet, kitchen and/or bathroom. Never combine the outside water system with that of another system (such as the engine).

Install the outside water pump as shown in the figure below. Take care to place the outside water pump at least 10 centimetres below the waterline of the ship. This position is necessary because the pump is **not** self-priming.

A blanking plug (N10322) and water filter (N10323) are part of the scope of supply. These parts should be installed directly on the skin through hull fitting. Use suitable material for making a water tight seal when screwing on these parts.

Install the skin through hull fitting (N10321) on the hull of the ship on the water line.

Connect components of the outside water system with the sea water resistant hose of 20 mm diameter (internal) as shown in the figure below. Always use 2 hose clamps for each connection on hoses placed below the waterline of the boat. Make sure that the hoses do not create tension on the housing of the outside water pump.

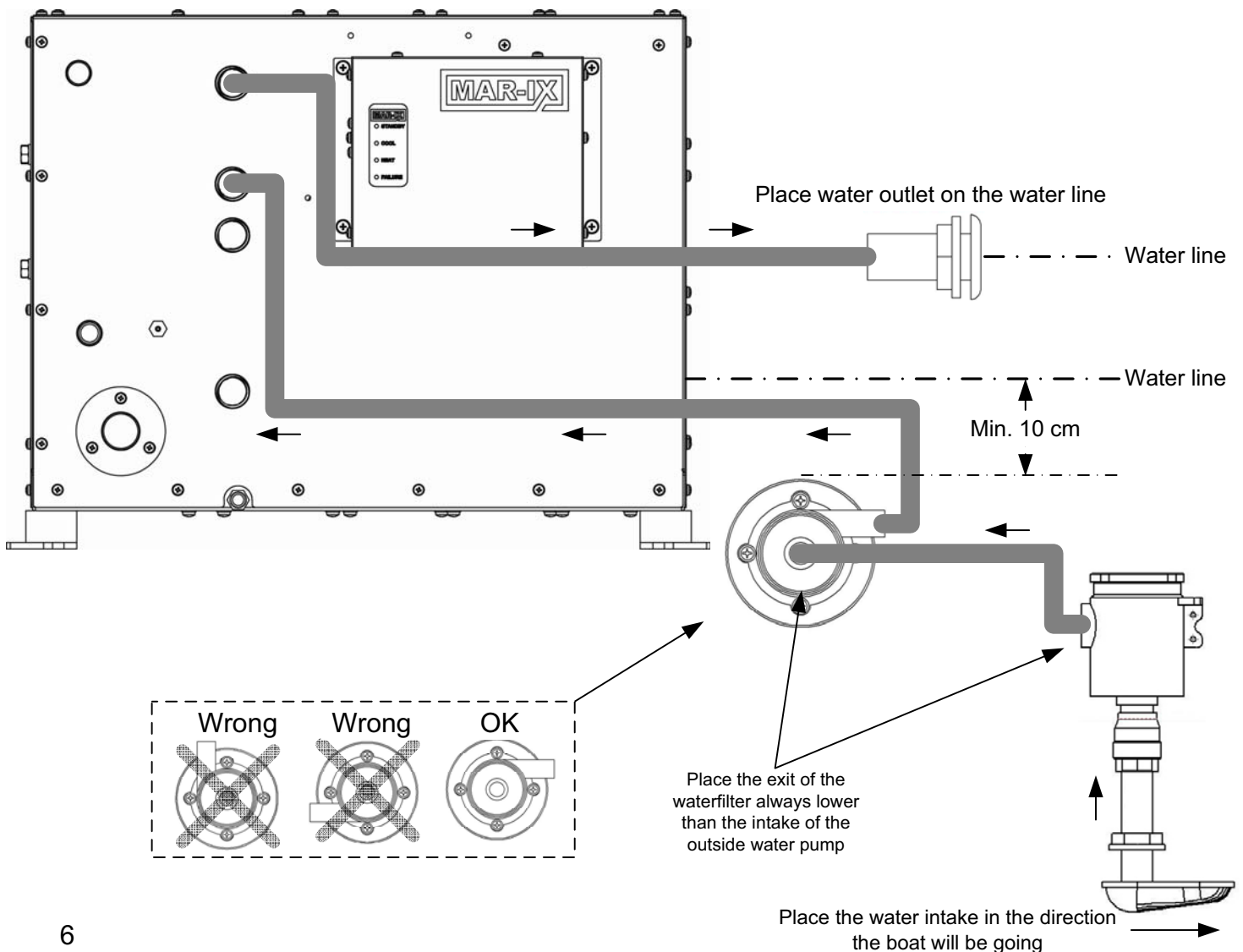

4. Installation

The way in which the closed cooling liquid system is built is shown in the figure below.

Installation:

It is recommended first to determine where the main components will be placed.

After this the placement of the 25 mm main hoses can be determined. It is recommended to install these hoses with insulation material in one attempt from the front to the back end of the ship and to mark these hoses as input and exit for the outside water. After determining the placement of the fan coil units the T-pieces (25x16x25) can be inserted in the 25 mm water hoses. The lower connection on the fan coil units can be connected to the 25 mm hoses which supplies the water. For this connection the 16 mm tube with insulation must be used. The upper connection on the fan coil units can be connected with the exit hose using the 16 mm hose with insulation.

The reservoir must be placed in a position **higher** than the highest fan coil unit. The middle connection of the reservoir must be connected with a T-piece (25x25x25) to the return hose.

The lower side of the reservoir must be connected to the input of the circulation pump.

The exit of the circulation pump must be connected to the input (upper connection) of the system cabinet. The exit (on the lower part) of the system cabinet is connected to the supply line. See the next page for the detailed drawing.

We advise to pressurize the system using max. 1 bar of air pressure and to check afterwards for leaks using soapy water. After this the fittings need to be insulated with insulation tape. This is to prevent condensation of the blank parts.

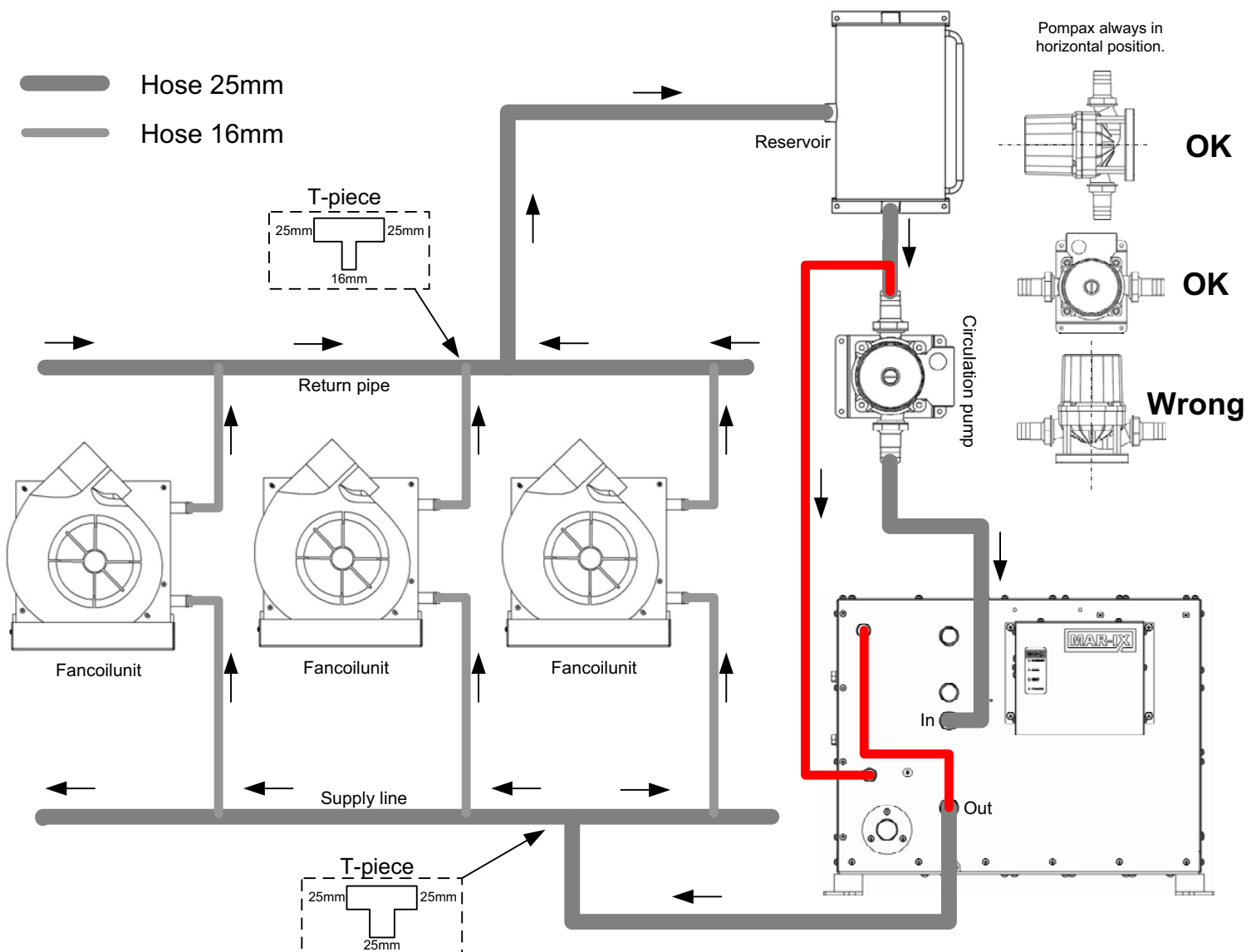

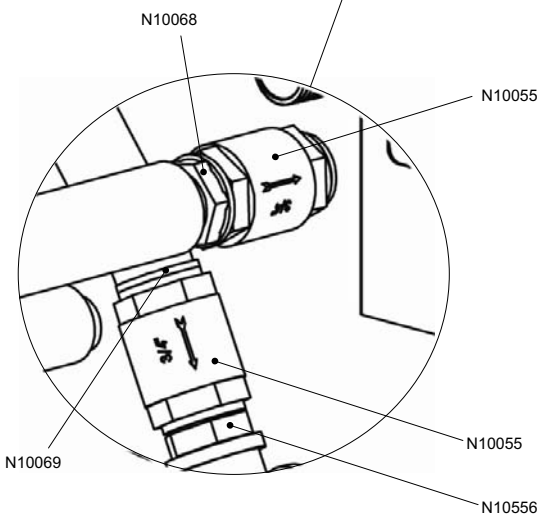
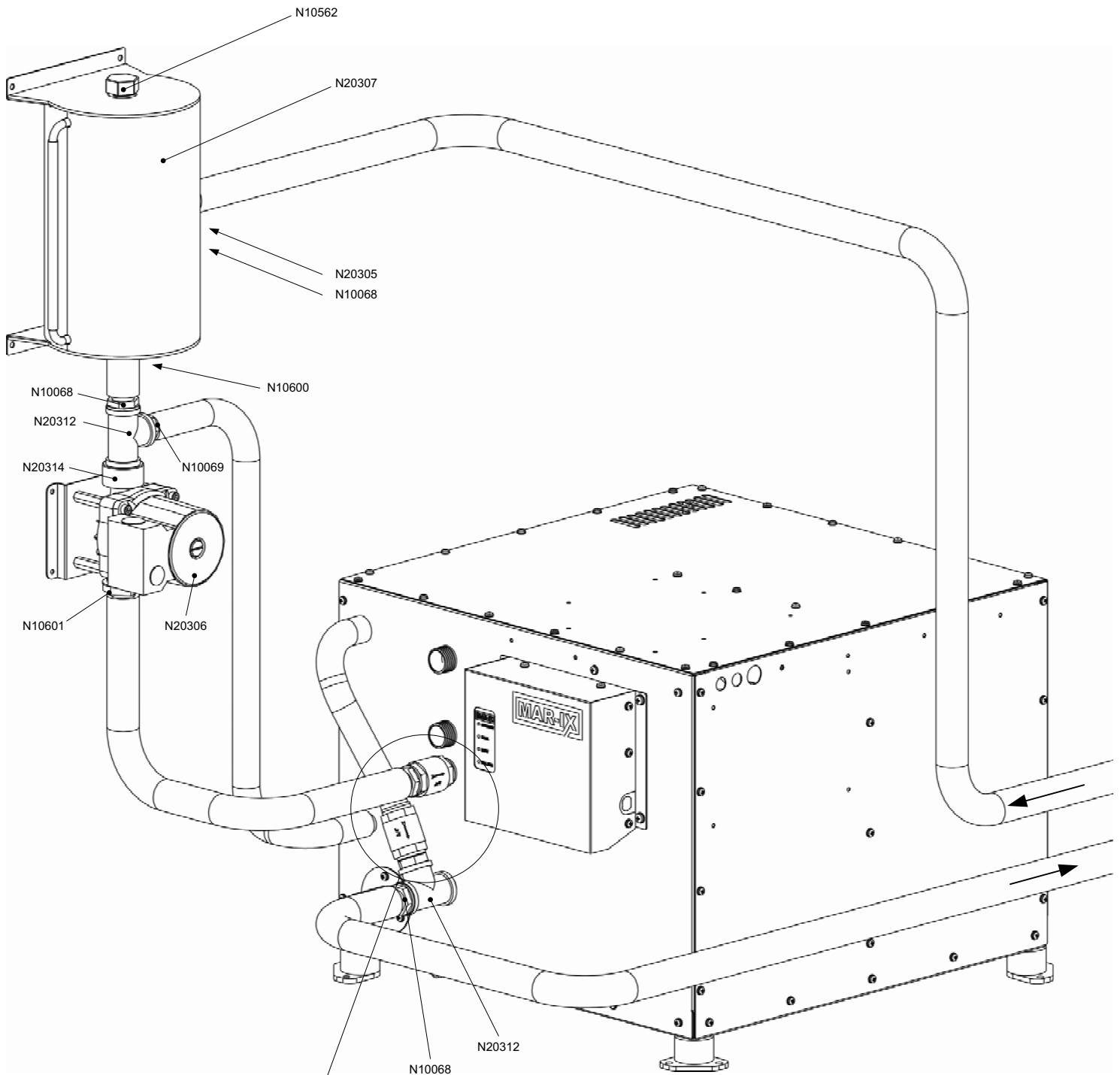

5. Exhaust system

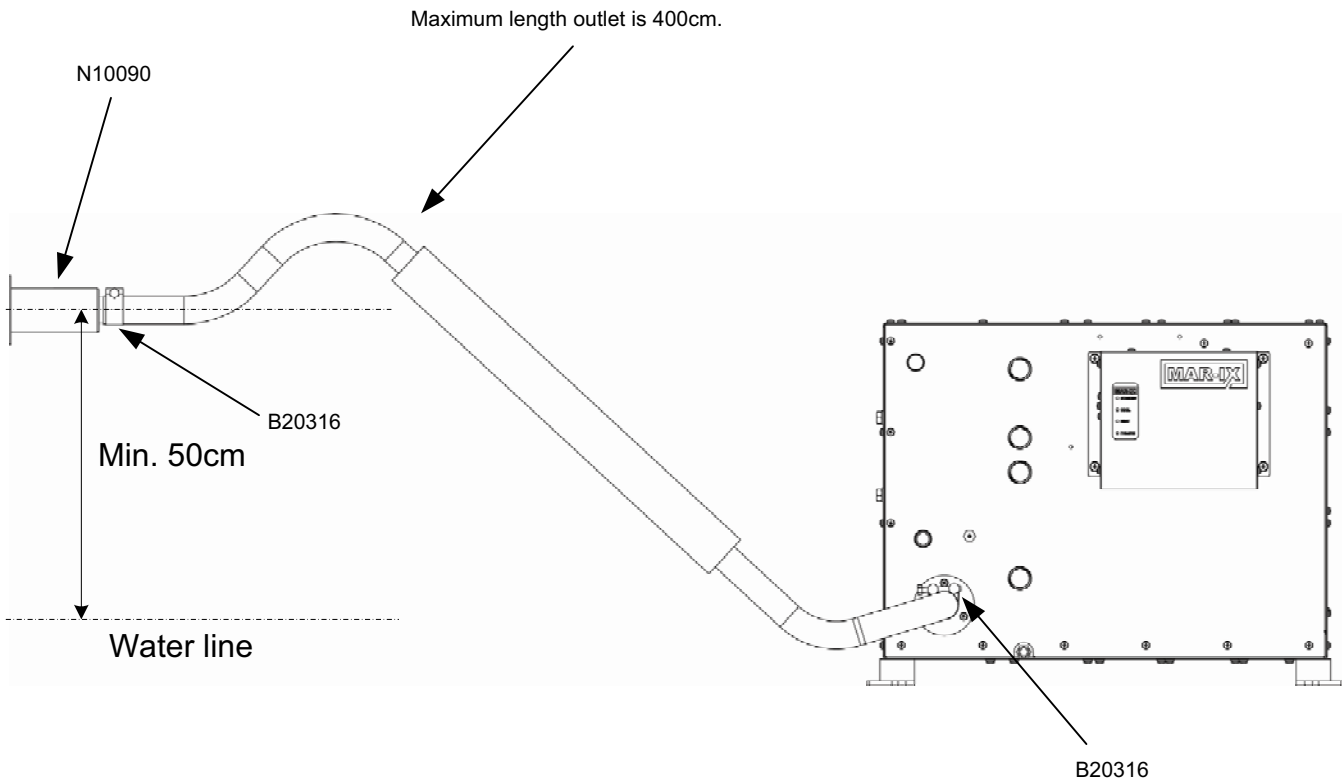

The exhaust fumes must always be directed to the outside air. Install the exhaust system as shown in the figure above. Make sure the exhaust outtake (N20315) is always placed at least 50 centimeters above the waterline. Exhaust fumes must never be vented in the engine room or the interior of the boat. Install the venting tube with a swan's neck. Make sure the venting tube is firmly attached using the hose clamps. (N20316) Use clamps every 50 centimeters to fix the exhaust hose.

Attention: the exhaust pipe will reach high temperatures!!! Make sure the exhaust can never touch combustible materials.

6. Fuel Supply

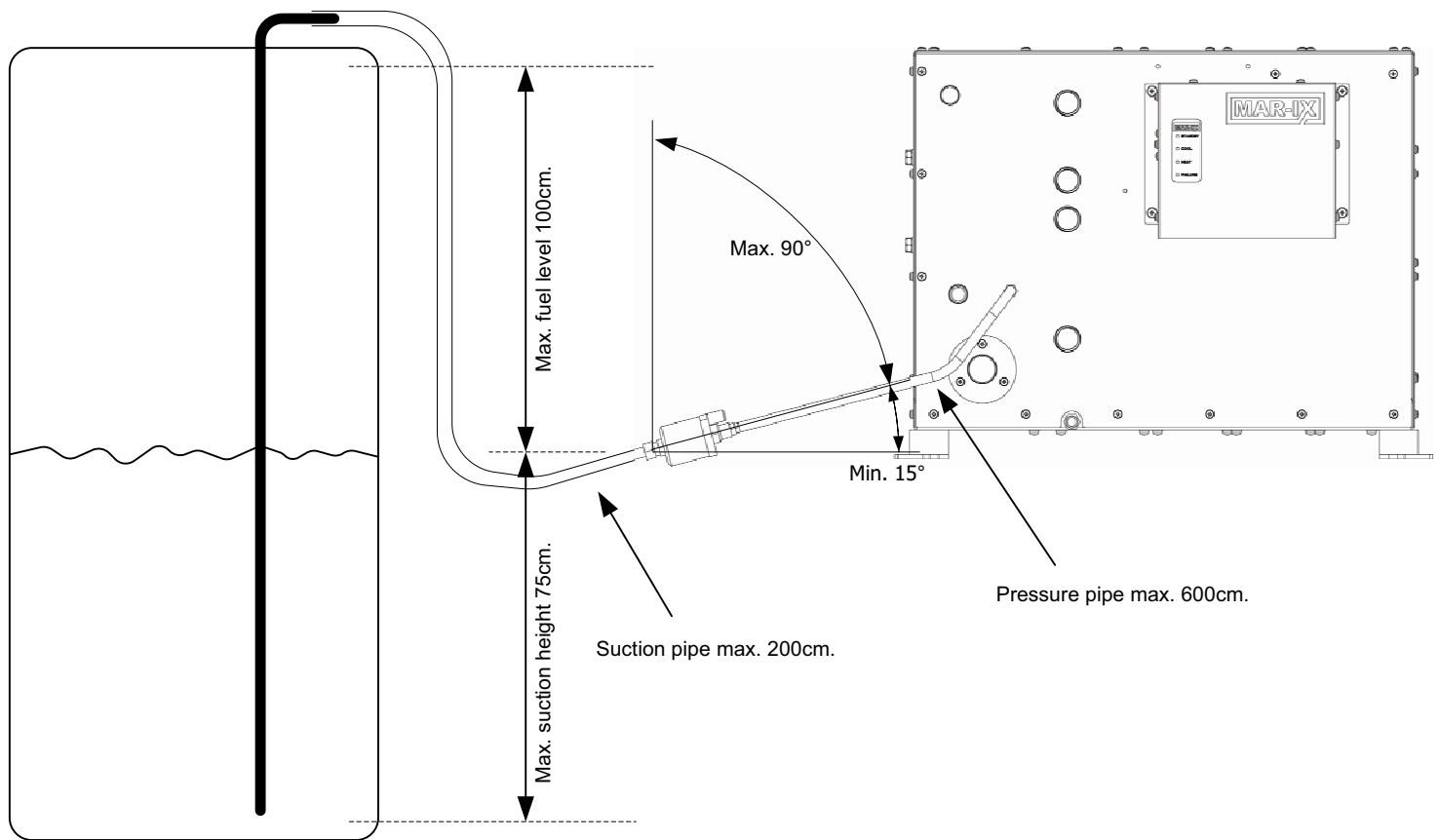

Connect the fuel system as shown in the figure above. Take note of the suggestions made in this figure. Install the fuel pump under an angle of minimally 15 degrees as shown in the figure. The connection can also be made with a T-piece in the fuel supply line of the engine.

Make sure the fuel lines are completely closed, this prevents that fuel will run back into the tank when the heater is out of service,

Use the hose clamps to secure the fuel line.

7. Condensation water drain

On the lower side of the system cabinet is a drainage for condensed water (see figure). This drainage will hardly produce any water at all. Still it is advised to make a connection to above mentioned systems too.

This can be done in several ways:

- By a skin through hull fitting direct to the outside water.
- By a connection on the drainage of the sink.
- By a connection on a shower water pump or drainage pump.
- By a connection on the outlet hose of toilet or bilge water tank.
- By a connection to the end of the bilge pump outlet.

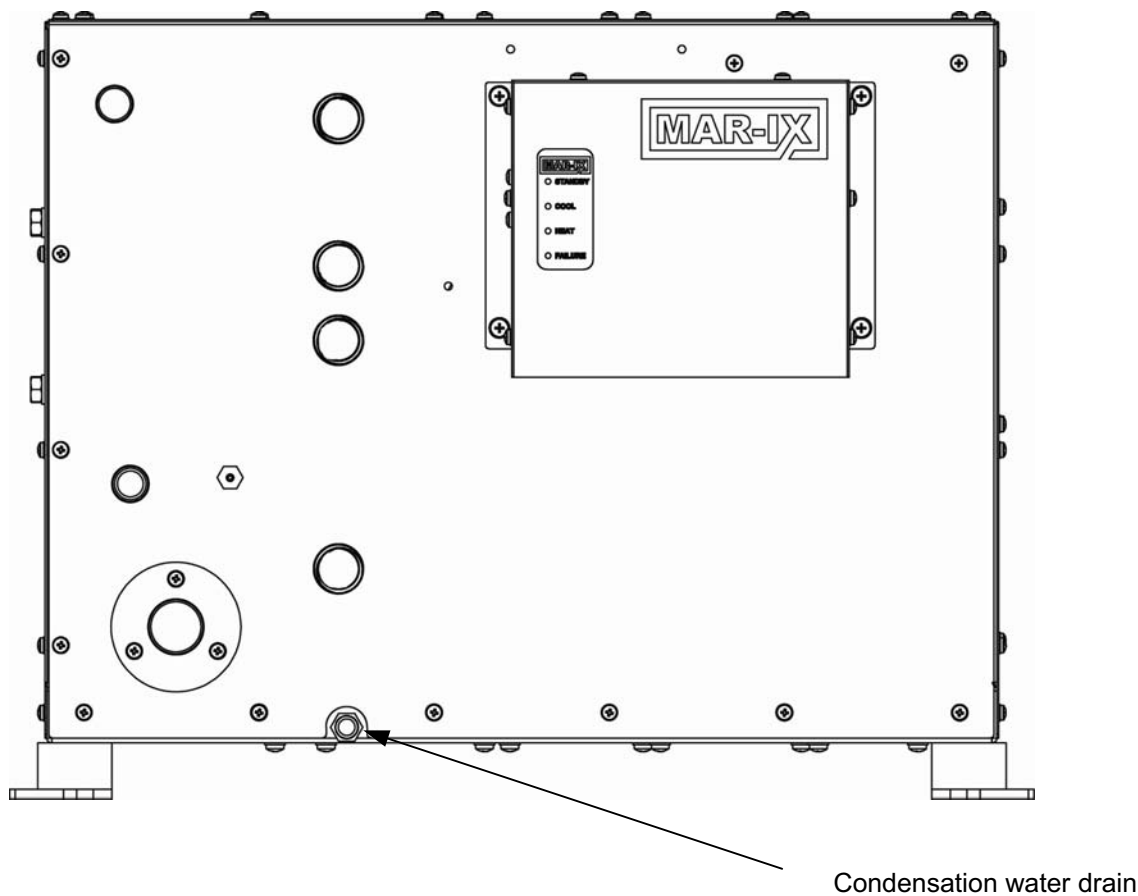

8. Electrical connections

To get access to the electrical connections you need to undo the screws which are indicated by arrows in the figure on the left. Next take off the front panel.

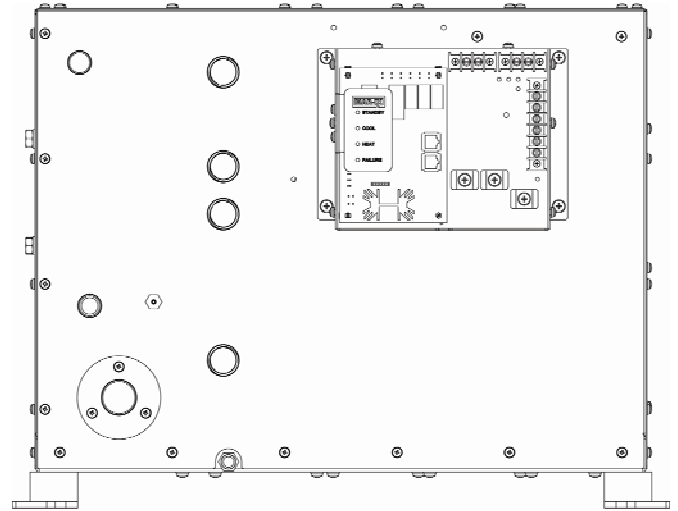
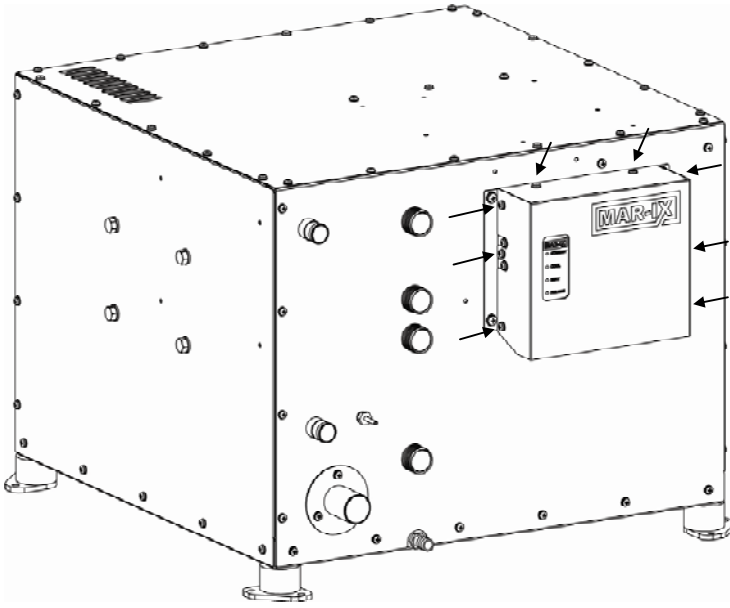

After taking of the front panel the electrobox is visible. In the figure below an schematic overview is given of the components which need to be connected. On the next page the connection are shown.

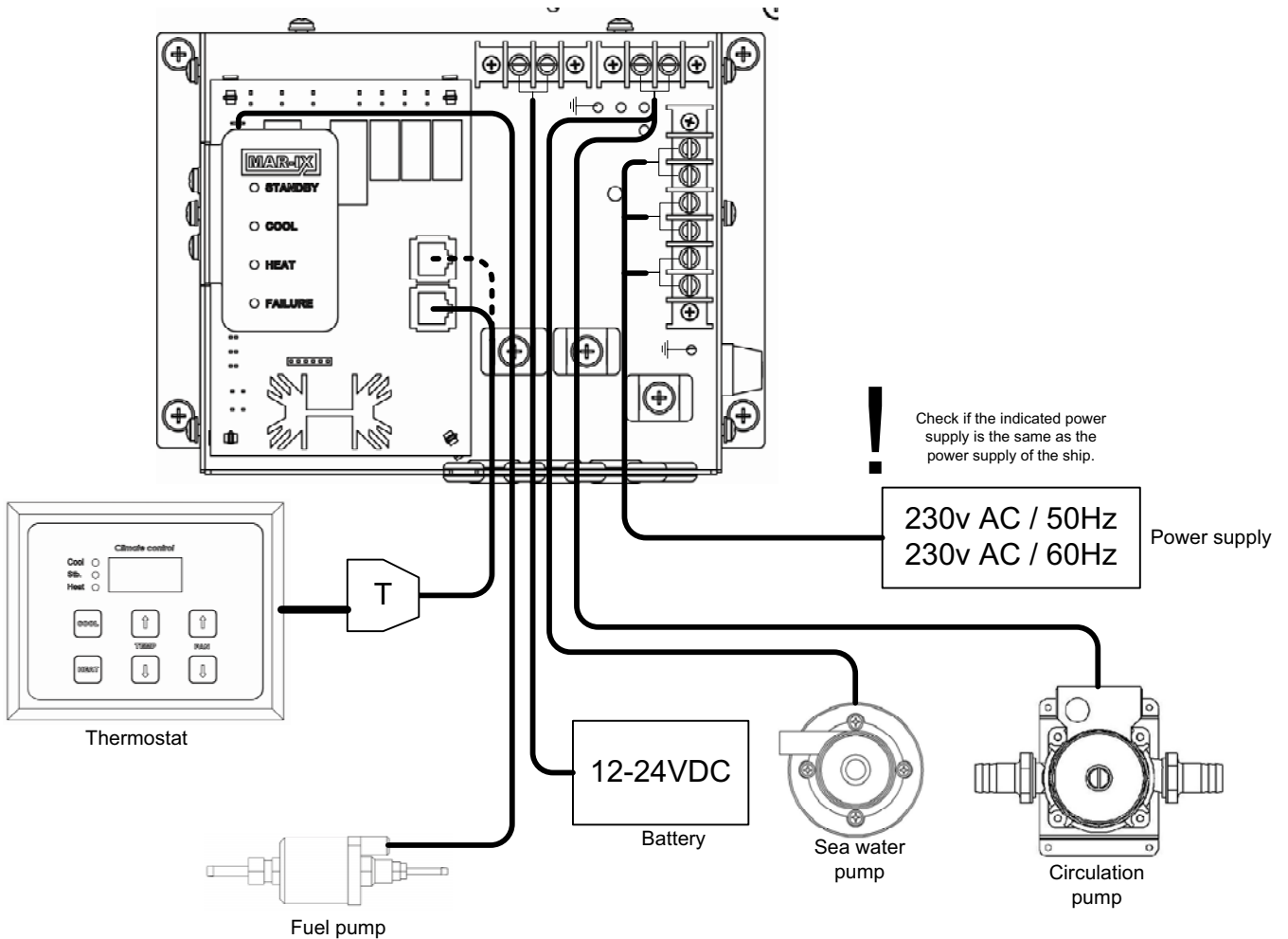

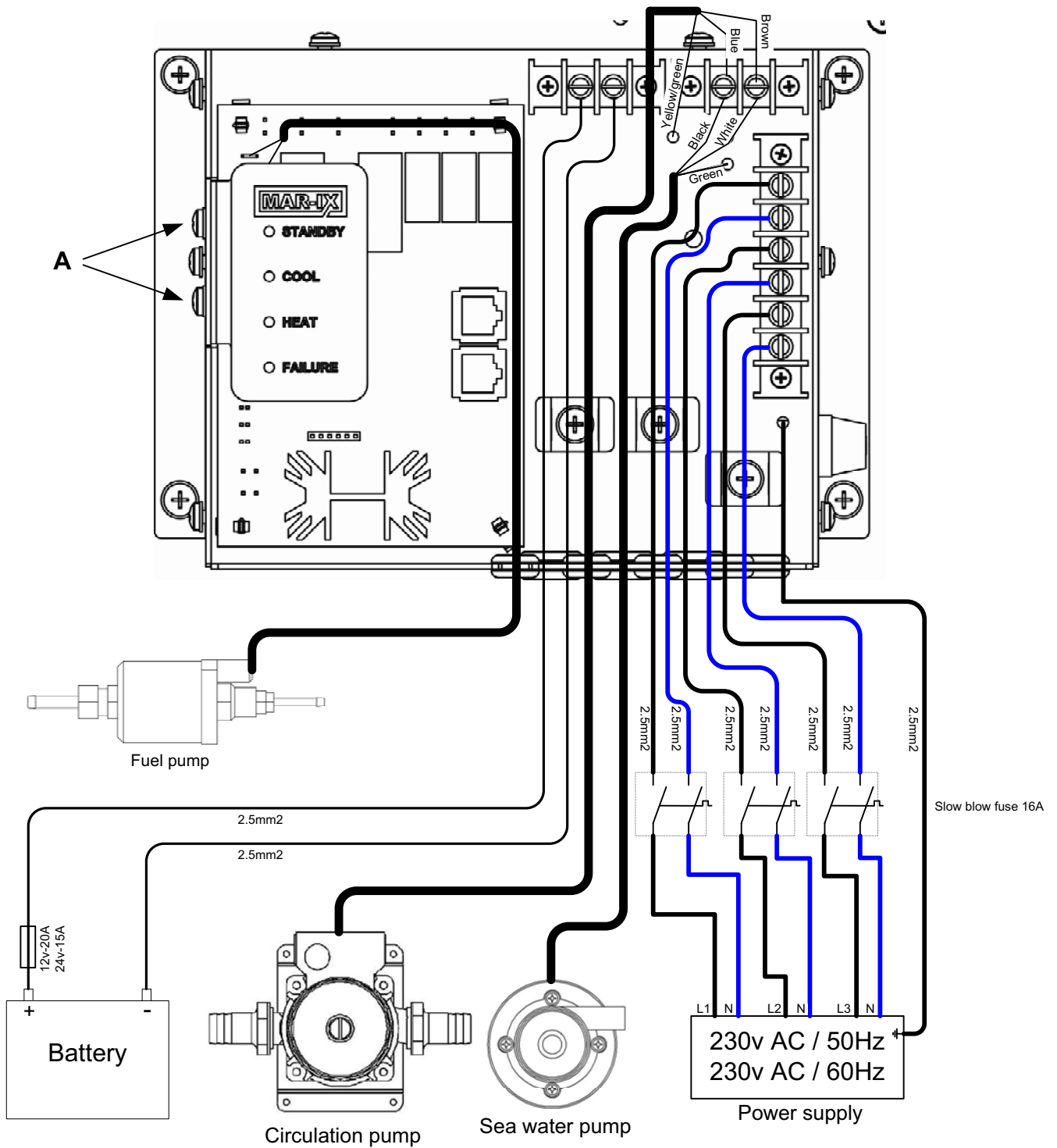

Connections:

The battery is connected using a cable with a minimum of 2,5 mm². The Fuse in this circuit is for an 12volt installation 20A and for an 24volt installation 15A.

The power supply must be connected by using a cable with a minimum of 2.5mm² which is suitable for 230 volt alternating current and a slow blow fuse of 16A needs to be used.

Check if the voltage and frequency of the boat are similar to the indicated voltage and frequency on the system label of the system cabinet. The ground cable needs to be connected to a connection on the bottom panel of the electro box.

The cirulation pump and sea water pump need to be connected as indicated in the figure above together with cables in the delivered package and the cables wich are mounted on the pump. The ground cable needs to be connected using the connection on the bottom panel of the electrobox.

The fuelpump for the heater must connected on the connection on the PCB with the text "fuel pump". This connection is positioned under the control panel. The control panel can be removed by losen the the screws indicated with "A".

The connecting of the thermostat is described in the manual of the thermostat itself, this is because the connections differ for each type.

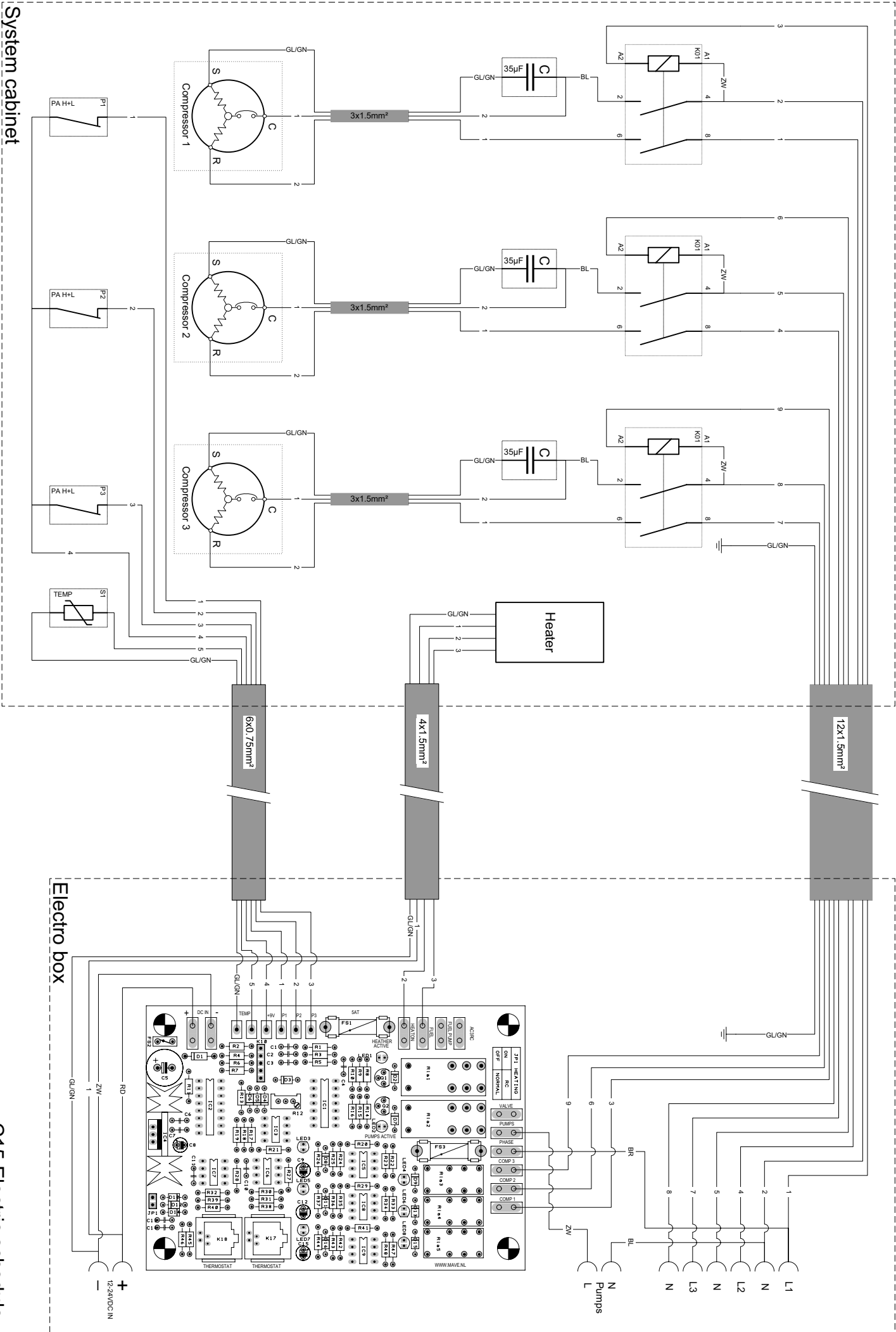

C15 Electric schedule

10. Technical data

C15	
<i>Dimensions (lxwxh)</i>	758x514x418 mm
<i>Weight</i>	126 kg
<i>Cool capacity</i>	15 kW (51.200 Btu)
<i>Refrigerant</i>	1500 gram R407C
<i>Number of compressors</i>	3
<i>Voltage</i>	230v 50Hz-ac and 12 or 24v dc
<i>Heat capacity</i>	9 kW (diesel)
<i>Electric power consumption (heat)</i>	36-125W
<i>Power supply AC</i>	230v/50Hz
<i>Power supply DC</i>	12 or 24 volt (depends on the heater)
<i>Power intake AC</i>	15A
<i>Power intake DC (12v)</i>	11A max.
<i>Power intake DC (24v)</i>	6A max.
<i>Outside water connection</i>	2x G3/4" ot
<i>Chilled water connection</i>	2x G3/4" ot
<i>Max. environmental temperature</i>	40°C
<i>Max. temperature outside water</i>	35°C

Description of the above mentioned system

The above mentioned system is equipped with three rotary compressors and is filled with an environmentally friendly R407C cooling gas.

The casing is made of corrosion resistant steel 304.

The water cooled condensor is built up using a sea water resistant copper/nickel.

C15 Dimensions

Size	Scale	Projection
A3	1:6	

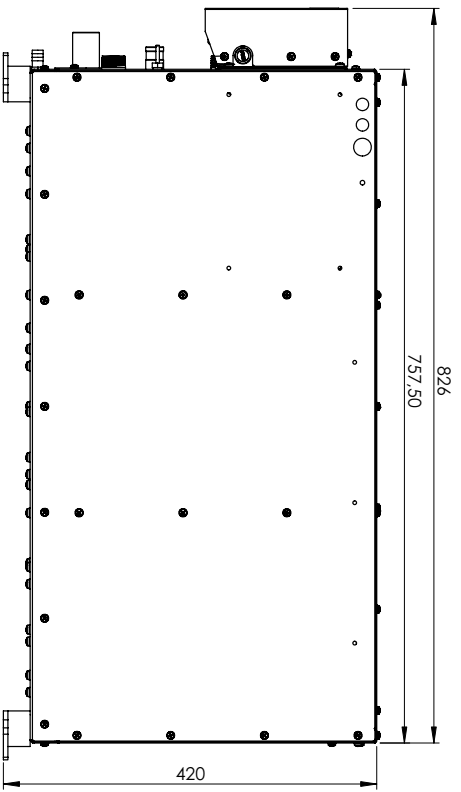
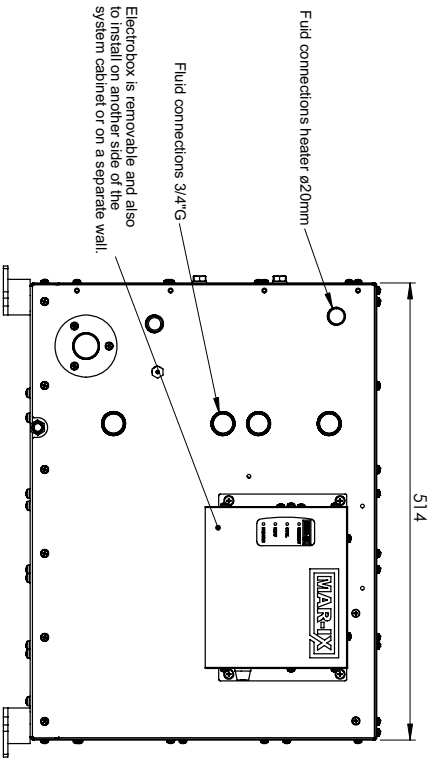
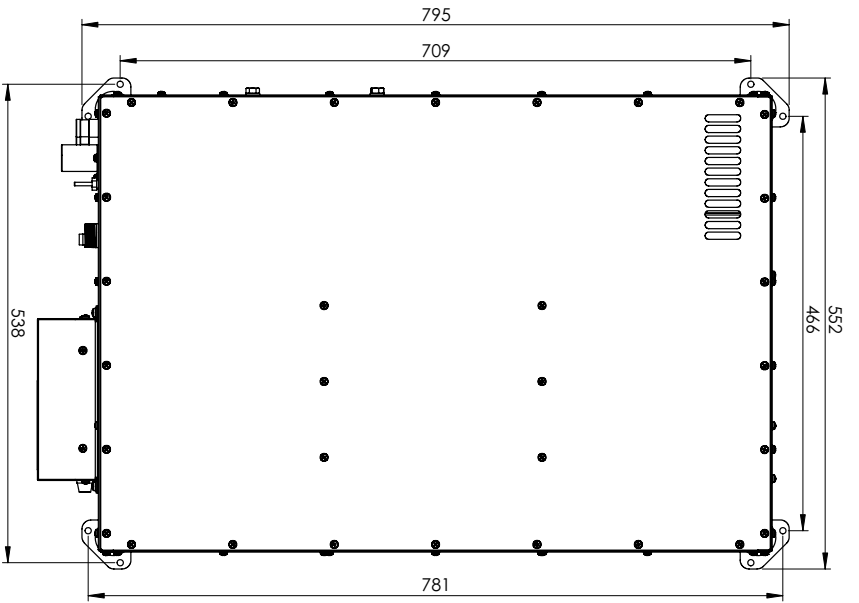

Electrical box is removable and also to install on another side of the system cabinet or on a separate wall.

Fluid connections heater ø20mm

Fluid connections 3/4" G

12. Preparations for use

After installation of the complete system, it needs to be put in operation for the first time. The following steps must be taken in the given order;

Connect a standard electric plug to the circulation pump.

- Fill the closed liquid system with a cooling liquid or antifreeze diluted with water. The liquid must be resistant to a minimum temperature of -10°C .
- Now the circulation pump must be switched on (on the standard electric plug).
- Refill the closed liquid system up to a normal level again, the circulation pump will pump the fluid through the system.

Make sure the cooling liquid level stays beneath the middle connection of the reservoir while filling up the system. Keep filling the closed liquid system until the level does not drop any more.

- Check if the fluid runs through the system. This is audible or can be seen when looking on the top of the reservoir using a torch light.
- Bleed all the fan coil units of air by screwing loose the nipples for taking air bubbles out on top of the fan coil units. Be sure the reservoir stays in level, or refill with fluid. We advise to check the liquid level of the reservoir, after bleeding each separate fan coil unit, and refill if necessary.
- When the system is bled of air the reservoir must be filled up to ± 5 cm **above** the middle connection.
- Reconnect the circulation pump according to the scheme on page 13.
- Open the water valve on the outside water system.
- Turn on the power supply of the airconditioning system (AC and DC power supply).
- Set one of the thermostats on cooling (see manual for the thermostat).
- Check if the water of the outside water systems runs through well.

Heating

- Switch on the heating function on one of the thermostats (see manual for the thermostat).

When using the heating system for the first time the heater will not turn on. The fuel must be pumped through the pipes to the heater. The heating system must be tried to restart several times. When the heater turns off the thermostat must be turned off and back on again. If the heater after several attempts still doesn't turn on the fuel supply must be checked.

When the heater turns on then a check must be made to see if the closed liquid system is warming up and the fluid is flowing through normally.

The system is now ready for use.

13. Maintenance

Outside water filter: Clean the filter depending on your level of use, but at least once every 3 months.

Close the outside water valve (N10322) beneath the filter.
Remove the cover from the filter.
Take out the filter element and clean the filter by using a brush and water until residue and filth is removed.
Check after reinstalling the filter and opening the outside water valve, if the filter cover does not leak any water.

Condensor: The condensor which is cooled by outside water must be decalcified at least once every year.

Close the outside water valve (N10322) beneath the filter.
Remove the water out of the sea water system by screwing loose both of the connections of the condensor.
Connect the lower hose back on the condensor.
Use the upper hose to fill the system with cleaning vinegar (8%).
Let the system stand filled with cleaning vinegar for at least 2 days.
Check after reassembly and opening of the outside water valve if the hoses connected to the condensor do not leak any water.

14. Preparing for winter

If the boat during winter will be subjected to the temperatures below freezing point then the water must be removed from the outside water system and must be completely flushed through with antifreeze.

Take off the hoses from the chiller and let the system empty as far as possible.

Reconnect the lower tube to the condensor.

Fill the condensor using the upper connection with antifreeze until it runs out of the ship.

Make sure no water can get into the system afterwards.

In areas where there will be no temperatures below freezing point the outside water system must be filled with fresh water or cleaning vinegar.

15. Fault finding (airco function)

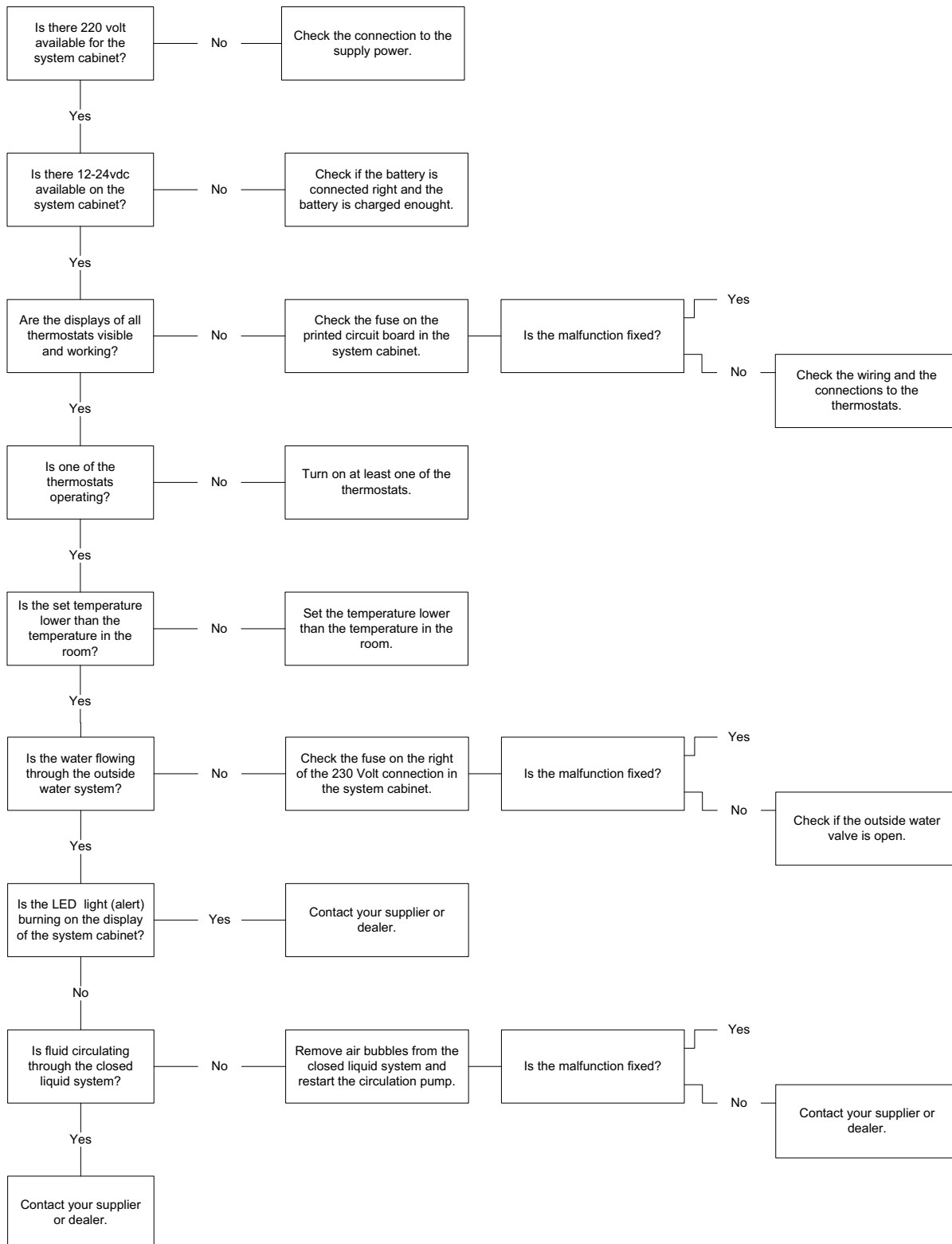

16. Fault finding (heating function)

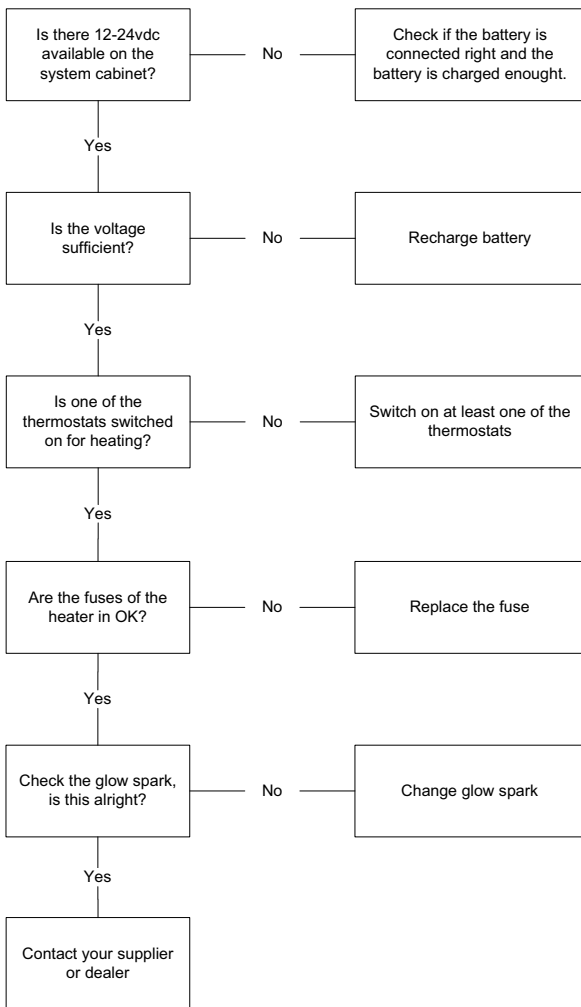

Declaration of Conformity

Mavé B.V. the Netherlands, certifies that all manufactured chillers and AC units have been tested and subjected to the following test procedures:

Pressure test.

The complete installation has been pressure tested with dry N2 according to European and Dutch regulations.

All units have been tested on at least 1.0 times the maximum working pressure with a maximum of 1.3 times the maximum working pressure.

The design pressure of any component is not lower than the maximum working pressure of the refrigeration system or section of the system in which that component is used.

During the testing period the installation has been checked on leakage and deformation.

Testing values.

R410a units.

This testing pressure on the low pressure side was ≥ 2500 KPa(g) $\approx 43^\circ\text{C}$.

This testing pressure on the high pressure side was ≥ 2600 KPa(g) $\approx 43^\circ\text{C}$. (water cooled)

R407c units.

This testing pressure on the low pressure side was ≥ 1750 KPa(g) $\approx 43^\circ\text{C}$.

This testing pressure on the high pressure side was ≥ 1750 KPa(g) $\approx 43^\circ\text{C}$. (water cooled)

R134a units.

This testing pressure on the low pressure side was ≥ 1000 KPa(g) $\approx 43^\circ\text{C}$.

This testing pressure on the high pressure side was ≥ 1000 KPa(g) $\approx 43^\circ\text{C}$. (water cooled)

Vacuum test.

Installations with a refrigerant charge < 10 kg.

A vacuum test has been performed by a vacuum of < 270 Pa and a minimal holding period of 30 minutes.

Refrigerant charge.

The unit has been charged according the number of kilograms mentioned on the identification plate.

Guidelines and environment.

Mavé B.V. the Netherlands commits herself to deliver the refrigeration installation according to the:

- EN 378 European safety and environment regulations for refrigeration installations and heat pumps
- CE standard
- The Dutch regulations on leak-free refrigeration equipment version 1997 or later.

M. Vermetten,

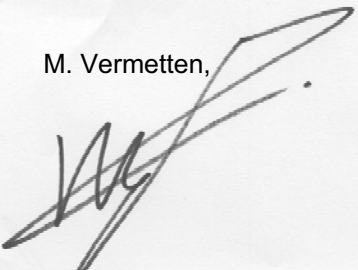

Managing director Mavé B.V.



Lisdoddeweg 21 - 8251 SM Dronten - The Netherlands
Tel.: +31(0)321-337467 - Fax: +31(0)321-337542
Web: www.mave.nl - Email: info@mave.nl